

Angled Bat Ridge Roost

Code: **GBAT-A**

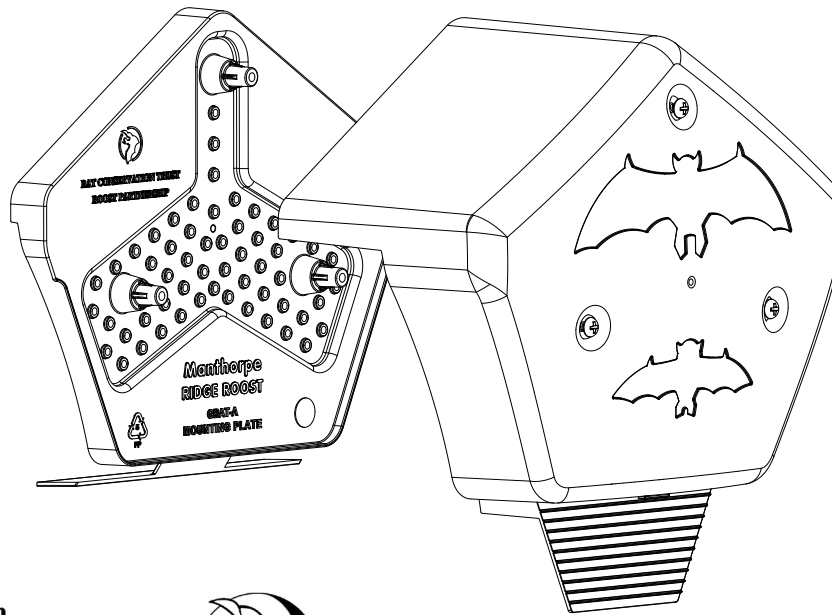

Roost Partnership with
Bat Conservation Trust

www.bats.org.uk



Description

The product provides a habitable roost space for small crevice-dwelling bat species found in the UK. The product is a self-contained, externally mounted unit which offers no means of access for the bats to enter the roof space or the property.

The Bat Ridge Roost is optimised to work in conjunction with the Manthorpe SmartVerge Polypropylene handed and ambidextrous dry verge systems (alternatively, could also be used with third party dry verge, traditional verge tiles or mortared in verge details).

The dual purpose product, also acts as a ridge end cap, providing a durable and protected covered finish for most styles of angled ridge tiles and is located at the end of the ridge tiles on a gable end.

The Bat Ridge Roost is made up of two units:

1. Mounting Plate
2. Cover Plate Assembly - Pre-assembled

The cover plate assembly is a pre-assembled part which houses the bat habitat and insulation with three pre-fitted screws. Please see the fitting instructions for further information on fixing the Bat Ridge Roost.

Features

- Fast and easy to install, dry fix system.
- Provides a protected roost for small bats to inhabit.
- Roost is fully enclosed with no access to the property.
- Part of the Bat Conservation Trust Roost Partnership
- Creates a thermally stable environment for the bats to roost.
- Designed for most angled concrete and clay ridge tiles.
- Provides a mechanically fixed, mortar-free solution.
- Protects the ridge end from exposure to the elements.
- Suitable for new build and refurbishment details.
- Can be installed on roof pitches between 15° and 55°.
- Drains water away from the wall to prevent staining.
- Manufactured from UV stabilised polypropylene.

MANTHORPE BUILDING PRODUCTS LTD
MANTHORPE HOUSE
BRITAIN DRIVE
CODNOR GATE BUSINESS PARK
RIPLEY
DERBYSHIRE DE5 3ND

TEL: 01773 303 000
FAX: 01773 303 300
EMAIL:
mbp.care@manthorpebp.co.uk
WEB:
www.manthorpebp.co.uk

DRAWN	ISSUE DRAWN
D.W. 18/09/25	D.W. 18/09/25

The company maintains a policy of continuous development of its product range and reserves the right to amend the specification without notice.

DRG No

MBP 8398

Issue

01
1 of 2

Angled Bat Ridge Roost

Code: **GBAT-A**

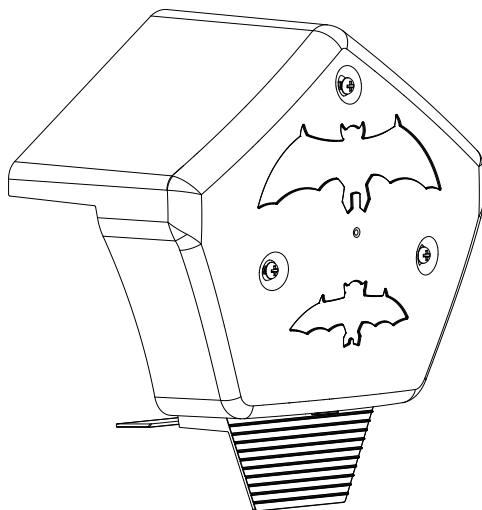
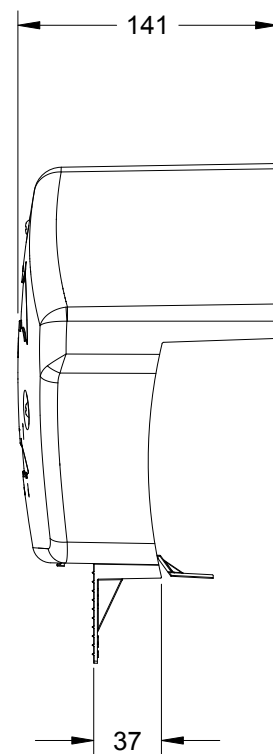
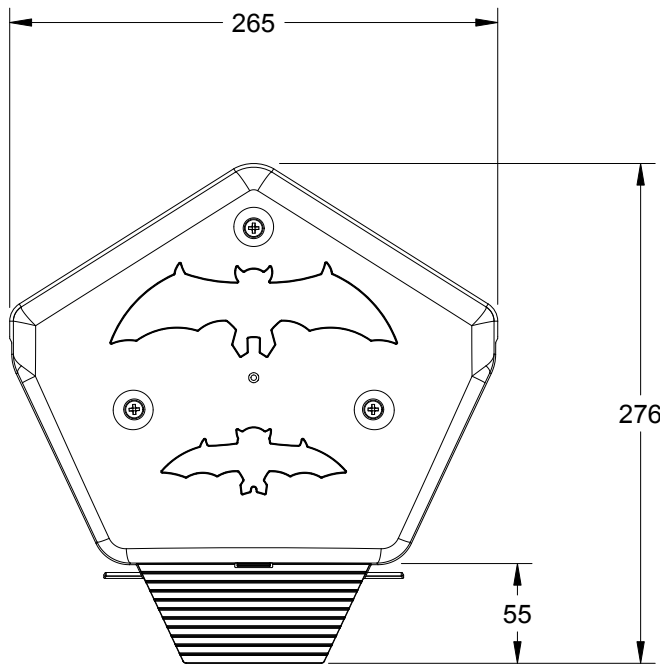

Bat entrance located on the base of the cover plate with a Bat Conservation Trust approved opening of 20mm x 16mm

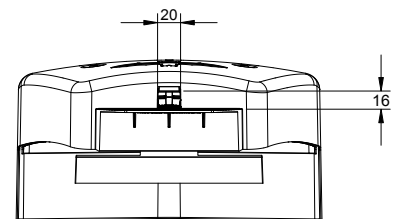

Packing Detail	1 per box
Box Weight	0.7 kg
Part Weight	0.5 kg

Additional guidance and information can be found in the Fitting Guide (MBP_GU_1397) and the Ecologist Guide (MBP_GU_1356).

Ridge Tile Compatibility	Angled ridge tile
Material	UV Stabilised Polypropylene
Manufacturing Process	Injection Moulding
Colours (Cover Plate Only)	(BL) Black (AR) Antique Red (GR) Slate Grey (BR) Brown (TR) Terracotta

MANTHORPE BUILDING PRODUCTS LTD
MANTHORPE HOUSE
BRITAIN DRIVE
CODNOR GATE BUSINESS PARK
RIPLEY
DERBYSHIRE DE5 3ND

TEL: 01773 303 000
FAX: 01773 303 300
EMAIL:
mbp.care@manthorpebp.co.uk
WEB:
www.manthorpebp.co.uk

DRAWN	ISSUE DRAWN
D.W. 18/09/25	D.W. 18/09/25

The company maintains a policy of continuous development of its product range and reserves the right to amend the specification without notice.

DRG No	Issue
MBP 8398	01 2 of 2