

# **MECFLOW** SUPPLY SYSTEMS



## THE FUTURE OF SUPPLY SYSTEMS

MECFLOW FUSION DESIGN, SPECIFICATION AND INSTALLATION GUIDE

# Contents

SECTION 1	Welcome to Polypipe	Page
	Welcome to Polypipe	4 – 5
SECTION 2	Introducing MecFlow	
	Introducing Supply Systems and MecFlow Fusion	6 – 7
	Features and benefits	8 – 9
	Applications	10 – 11
SECTION 3	Product list	
	Manifolds	12 – 15
	Pipe and Fittings	16 – 27
SECTION 4	System sizing	
	System sizing	28
	Diameter equivalence MecFlow Fusion and copper pipes	29
	Diameter equivalence MecFlow Fusion and steel pipes	30 – 31
	Co-efficient of loss by product type	32
	MecFlow Fusion temperature and pressure ratings	34
	MecFlow Fusion pressure loss	35 – 45
SECTION 5	Technical specification	
	Technical specification	46
	System description	47
SECTION 6	Joining methods	
	Joining methods	48 – 50
	Socket fusion welding	51 – 54
	Butt fusion welding	55 – 60
	Electrofusion welding	61 – 65
SECTION 7	Installation	
	Installation	66
	System bracketing	67
	Thermal movement	68 – 77
SECTION 8	Chemical resistance	
	Chemical resistance	78 – 87
SECTION 9	System commissioning & maintenance	
	System commissioning & maintenance	88 – 91
SECTION 10	Approvals	
	Quality management system and assurance	92 – 93
	Manufacturing standards	94 – 95
SECTION 11	Polypipe Advantage and MecFlow Fusion Support	
	Polypipe Advantage and MecFlow Fusion support	96 – 97
	Polypipe Building Services	98 – 99
	Terms and conditions	100 – 102



# 1. Welcome to Genuit and Polypipe — Building Services

We are a company proud to be a part of the construction industry. It's grown with us, and us with it. We understand the challenges today's projects face both from an economic and sustainability basis – having to prove best value, whole life costs and delivery within the project timeframe.

Because we work within our specific market sectors, with the many different types of people making up the project delivery team, we understand all the key touchpoints of a project, and we can provide design and product support right from the start through to completion.

## SUSTAINABLE WATER AND CLIMATE MANAGEMENT

At Polypipe, we're proud of our British heritage, which we continue to build on, helping our customers in all areas of construction to deliver the best possible project results, from water management to climate management.

For example, continued development of our Underfloor Heating Smart Controls to deliver more affordable, controllable energy. Drainage stacks that are developed and manufactured off-site and delivered to site complete and ready to install; saving on cost, labour, installation time and waste. Sustainable methods in which to store and reuse rainwater, using recycled materials where appropriate, to help cool inner cities whilst reducing the strain on potable water and sewers. And provide low-energy filtered clean air and heat recovery systems within buildings for a healthier, more comfortable living experience.

For more information on all our climate and water management solutions visit [polypipe.com](http://polypipe.com)



## SECTOR-FOCUSED TO UNDERSTAND YOUR VISION

Through experience and expertise, we have a detailed understanding of the complexity of our commercial customers' projects, the challenges that can arise and the applications in which our systems are used. Therefore, working within these environments and understanding the regulations required, we are able to deliver water management and climate management solutions that make a truly positive difference.

We know that it takes a team of different disciplines, from Client to Contractors, and those in between, to deliver it. And working closely with external influencers, we are able to establish and deliver the best results from the ground up – and down again.

## POLYPIPE BUILDING SERVICES

From schools, hospitals and tall buildings to shopping centres and commercial and industrial developments, Polypipe Building Services brings you more.

Created and developed to support you and your projects, Polypipe Building Services' innovative systems and solutions make it easier to create safe and sustainable commercial buildings.

More innovation, more expertise and more support, developing and delivering engineered drainage and water supply systems and services. From our trusted Terrain drainage solutions to MecFlow, our water supply system, we always look to advance new products and services that optimise on-site quality and productivity, so we can achieve more, together.

Dedication towards delivering quality, sustainable products and services means a great deal to us, our supply chain and our customers – and has been recognised by the BSI with ISO 14001, ISO 9001, ISO 45001 and BES 6001 accreditations.

## 2. MecFlow Fusion overview

### POLYPIPE BUILDING SERVICES

For decades, Polypipe Building Services has focused on its drainage specialism and is well known for its trusted, high quality Terrain drainage solutions. We've been working hard, leveraging our expertise in plastic pipework systems to bring you more, and we're proud to announce the introduction of MecFlow Fusion as part of our MecFlow Supply System.

MecFlow Fusion is a multi-layer, WRAS approved, PP-RCT pipe with a material formulation that has been designed for strength, durability and achieves a fire classification rating of B-s1, d0\*; making it ideal for hospitals, multi occupancy and tall building projects.

The system's white inner layer incorporates anti-microbial protection, preventing biofilm build-up and has a high resistance to rigorous disinfection processes. Heat and fluctuating temperatures won't phase MecFlow Fusion either. Its central layer benefits from the addition of microfibres set in a mesh formation, working to reduce thermal expansion and along with several other additives, increases the mechanical resistance of the system.

Finally, MecFlow Fusion's outer layer is UV stabilised and abrasion resistant, contributing to the system's robust construction, providing overall high resistance to impact, ensuring it's the confident choice when transporting, storing and handling on-site.\*\*

There are multiple ways in which you can experience the MecFlow Fusion system. From design through to procurement and installation.

1. Through our Polypipe Advantage service, we can work with you to design a bespoke system, fabricated to your project's specific requirements. This option includes our patented CLICKWELD™ technology.
2. Build your own system and procure our range of MecFlow Fusion products from trusted trade merchants.

Our products have been designed to help reduce installation time on-site using the latest off-site fabrication techniques.

\*Fire classification rating according to EN13501, installed according to building regulations. \*\*Please refer to storage and handling guidance on page 47.

© Polypipe MECFLOW // FUSION

  
POLYPIPE  
ADVANTAGE



MecFlow Fusion is all about simplicity, but to make procurement even more straightforward, our Advantage service can help. We'll help you formulate a solution that's perfect for your system, we'll manufacture it and test it off-site, then deliver it when you're ready.

# Features and benefits

## MECFLOW FUSION BENEFITS YOUR PROJECT MORE

With its multi-layer PP-RCT material formulation and unique CLICKWELD™ installation capabilities, MecFlow Fusion delivers the features and benefits you need to get the job done quickly, easily and without compromising on quality.

### MATERIAL



#### LOW NOISE TRANSMISSION

Due to its material properties the MecFlow Fusion system provides high resistance to the propagation of noise from water flowing at high velocities within its internal bore.



#### ANTI-MICROBIAL PROTECTION

The MecFlow Fusion system is manufactured using a patented material additive within the internal bore surface that prevents pathogens attaching and developing into bacterial colonies.



#### CHEMICAL RESISTANCE

MecFlow Fusion has excellent chemical resistance due to its high molecular weight and non-polar polymer structure. It is resistant to fluids from pH1 to pH14.



#### LESS ON-SITE STORAGE

Through the Polypipe Advantage service, MecFlow Fusion is delivered in sections exactly when you need it, reducing the need for long term on-site storage.



#### ABRASION RESISTANCE

The smooth and mechanically robust bore of the MecFlow Fusion system protects against material erosion due to the flow of aggressive fluids over long periods of time.



#### UV RESISTANCE

The MecFlow Fusion material formulation protects against oxidation by direct exposure to UV radiation from sunlight.

### DESIGN



#### TECHNICAL DESIGN

Worried you will have to wait for a technical design to be completed that could take weeks for the size of your project? The Polypipe Advantage team are on hand to support you with technical queries and our promise to you is to return a quote in a speedy fashion, for any enquiry.



#### TESTING

During manufacturing of the MecFlow Fusion product range, items will be constructed in a controlled environment with repeatable test methods. The results of which, ensures a high quality of MecFlow Fusion product arrives on-site, time after time.



#### CONNECTING MECFLOW COMPONENTS TOGETHER

The connection methods are simple, using known and trusted techniques including Butt Welding, Electrofusion and Socket Welding, the MecFlow Fusion range can be easily and efficiently connected. Alternative flanged and threaded connection options are also available as well as reducers to suit all connection requirements.



#### BIM

The MecFlow Fusion range is supported with a range of REVIT files designed to an approved BSI Kitemark. The tools provide the ability to design the system with a simple, pre-engineered, data rich 3D model and at the click of a button, you can transfer the design to us - to provide a quotation against it.

### INSTALLATION



#### CLICKWELD™ TECHNOLOGY

The unique CLICKWELD™ technology means no clamps are required for welding, the clips ensure a consistent weld and allow for pre-assembly before electrofusion welding for a secure, long-lasting joint.



#### LESS ON-SITE WASTE

Through the Polypipe Advantage service, MecFlow Fusion is delivered in pre-fabricated sections, so you get exactly what you need, reducing packing and on-site waste. What's more, Polypipe will recycle any offcuts or end caps at the end of your project.



#### MAXIMISED WATER QUALITY

The system's smooth bore and high chemical resistance maintains the quality of water supplied over the lifecycle of the MecFlow Fusion system.



#### INCREASED MECHANICAL STRENGTH

Due to the addition of micro-fibres to the material formulation, the MecFlow Fusion system has improved temperature and pressure characteristics giving it excellent mechanical strength over a range of fluid temperatures.



#### LOWER LABOUR COSTS

With the systems fast installation method and less labour required for installation, projects benefit from a reduction in labour costs.



#### SAFER INSTALLATION

No gas torches or naked flames needed for installation.

# Applications

The MecFlow Fusion system and its product range have been designed with flexibility in mind, to ensure ease of installation for a variety of applications.



## APPLICATION 1 - BOOSTED COLD WATER SYSTEMS (BCWS)

We typically provide two variations of design styles for this application.

- The first, as a riser with a high-level ceiling grid run-out along corridor spacing.
- The second, with a riser and connection to a riser cupboard (or similar) mounted manifold.

## APPLICATION 2 - LOW TEMPERATURE HOT WATER SYSTEMS (LTHW)

Whether connecting to ventilation systems and AHU's, or any other forms of Low Temperature Hot Water Systems, the MecFlow Fusion product range is simple to design and match to your requirements. As a flow and return system you can run concurrent risers, run-outs and connections. Utilise our Tee's, Reducers and Threaded Adaptor range to manoeuvre throughout the building and connect to all systems.

## APPLICATION 3 - CHILLED WATER SYSTEMS (CW)

Like the LTHW design, the CW system will likely operate on a flow and return basis. Often in larger pipe sizes and with a wide variation of connection sizes for plant. Our range provides the options needed to neatly run throughout the CW plant spaces and connect all aspects of the building's cooling system together.

## APPLICATION 4 - HEATING SYSTEMS (HS)

Many piping systems are often designed for specific applications to meet the everyday needs of their users' requirements. Heating systems come in a diverse range of design styles and we would highly recommend speaking with our technical team to ensure the MecFlow Fusion product range will meet all of your heating system requirements.



3D scan demonstrating how Polypipe can add value to your retro fit projects by scanning your building and overlaying with the exact MecFlow Fusion pipes and fittings you would need to complete your job.

## EXAMPLE SYSTEM 1 - AHU SYSTEMS

Air handling units used in many and varied applications to provide heating, cooling and filtration. For heating and cooling applications, either the LPHW or the CW pipework is suitable for the MecFlow Fusion system.

## EXAMPLE SYSTEM 2 - LTHW SYSTEMS

Heating systems predominantly used in conjunction with boilers for their energy saving qualities. The pipework for these systems is traditionally mild steel, however greater longevity and improved system performance can be achieved using MecFlow Fusion. Due to the chemical-resistant properties of the MecFlow Fusion inner layer, the build-up of debris within the system, which causes reduction in internal bore, increasing pressure whilst reducing flow rate, is irradiated.

## EXAMPLE SYSTEM 3 - CHILLERS

Chillers use a combination of hot gas, water and air as their medium. MecFlow Fusion is compatible for the water piping which would encompass both CW and LTHW.

## EXAMPLE SYSTEM 4 - FLUID BASED HVAC

Due to the rising cost and reduced availability of refrigerant gas, more systems are moving toward water and brines as the cooling or heating medium for HVAC applications in both commercial and light industrial applications. MecFlow Fusion is ideally suited to this application.

## EXAMPLE SYSTEM 5 - RETRO FIT AND REPLACEMENT

With fusion weld technology, MecFlow Fusion is the smart solution for paperwork replacement in any environment, providing minimum disruption, whilst enabling significant reduction in the levels of health and safety provision required.

## EXAMPLE SYSTEM 6 - DRY AIR COOLERS

Dry air coolers comprise small systems coupled to refrigerate plant and much larger installations used in data centre cooling applications, for example, outside air is the medium used for cooling the water or brine within the system, all of which can be piped using MecFlow Fusion. In addition, advancements in dry aircooler technology are moving toward Adiabatic spray systems. (Using sprayed water or saturated pads to reduce the ambient air temperature and increase efficiency). The MecFlow Fusion system, therefore is perfectly suited to this type of application.

## EXAMPLE SYSTEM 7 - COOLING TOWER

Cooling towers are more in the realm of heavy industrial plant, however, they would also benefit from a MecFlow Fusion system, coupled with its low risk, provides a logical alternative to traditional install methods, whilst encompassing CW, BCW and LTHW.

# 3. Product list

## Manifolds - Horizontal with drain cock

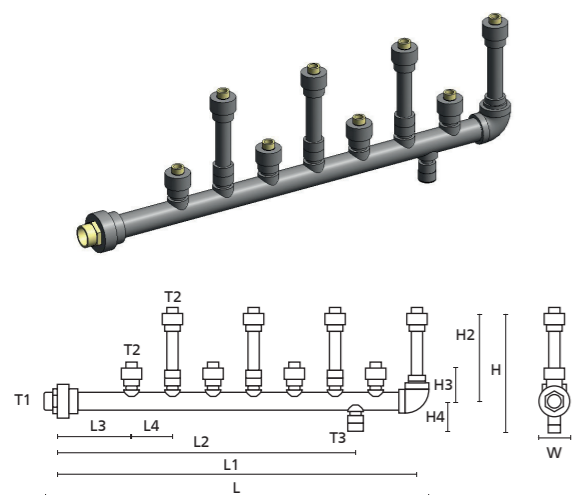

MANIFOLDS	NO. OF PORTS	LENGTH				
		TOTAL LENGTH L mm	TOTAL LENGTH (CENTRE) L1 mm	LENGTH TO DRAIN COCK L2 mm	LENGTH TO FIRST PORT L3 mm	LENGTH BETWEEN PORTS L4 mm
3808.50Y32075Y.2.HDX	2	428	365	200	255	110
3808.50Y32075Y.3.HDX	3	483	420	255	200	110
3808.50Y32075Y.4.HDX	4	593	530	365	200	110
3808.50Y32075Y.5.HDX	5	703	640	475	200	110
3808.50Y32075Y.6.HDX	6	813	750	585	200	110
3808.50Y32075Y.7.HDX	7	923	860	695	200	110
3808.50Y32075Y.8.HDX	8	1033	970	805	200	110
3808.50Y32075Y.9.HDX	9	1143	1080	915	200	110
3808.50Y32075Y.10.HDX	10	1253	1190	1025	200	110
3808.50Y32075Y.11.HDX	11	1363	1300	1135	200	110
3808.50Y32075Y.12.HDX	12	1473	1410	1245	200	110

## Manifolds

HEIGHT				WIDTH W mm	CONNECTION TYPES					
TOTAL HEIGHT H mm	LONG PORT HEIGHT H2 mm	SHORT PORT HEIGHT H3 mm	DRAIN COCK HEIGHT H4 mm		PRIMARY BSPM T1	PORT BSPM T2	DRAIN BSPM T3	PRIMARY	PORTS	DRAIN
321	235	85	86	85	1½"	¾"	½"	Male Threaded	Male Threaded	Female Threaded
321	235	85	86	85	1½"	¾"	½"	Male Threaded	Male Threaded	Female Threaded
321	235	85	86	85	1½"	¾"	½"	Male Threaded	Male Threaded	Female Threaded
321	235	85	86	85	1½"	¾"	½"	Male Threaded	Male Threaded	Female Threaded
321	235	85	86	85	1½"	¾"	½"	Male Threaded	Male Threaded	Female Threaded
321	235	85	86	85	1½"	¾"	½"	Male Threaded	Male Threaded	Female Threaded
321	235	85	86	85	1½"	¾"	½"	Male Threaded	Male Threaded	Female Threaded
321	235	85	86	85	1½"	¾"	½"	Male Threaded	Male Threaded	Female Threaded
321	235	85	86	85	1½"	¾"	½"	Male Threaded	Male Threaded	Female Threaded
321	235	85	86	85	1½"	¾"	½"	Male Threaded	Male Threaded	Female Threaded
321	235	85	86	85	1½"	¾"	½"	Male Threaded	Male Threaded	Female Threaded
321	235	85	86	85	1½"	¾"	½"	Male Threaded	Male Threaded	Female Threaded

## Manifolds - Horizontal with drain cock

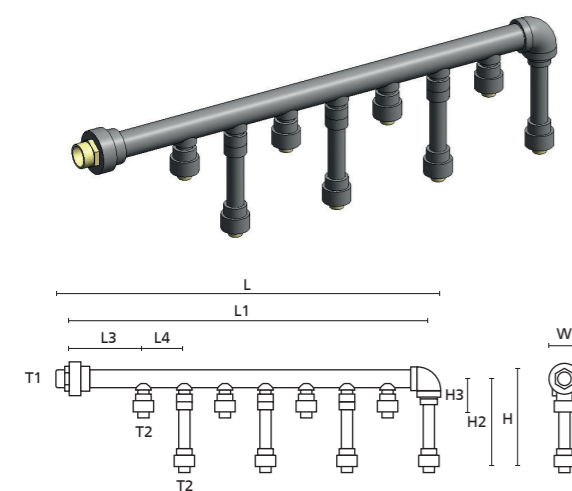

MANIFOLDS	NO. OF PORTS	LENGTH			
		TOTAL LENGTH L mm	TOTAL LENGTH (CENTRE) L1 mm	LENGTH TO FIRST PORT L3 mm	LENGTH BETWEEN PORTS L4 mm
3818.50Y32075Y.2.HX	2	373	365	200	110
3818.50Y32075Y.3.HX	3	483	420	200	110
3818.50Y32075Y.4.HX	4	593	530	200	110
3818.50Y32075Y.5.HX	5	703	640	200	110
3818.50Y32075Y.6.HX	6	813	750	200	110
3818.50Y32075Y.7.HX	7	923	860	200	110
3818.50Y32075Y.8.HX	8	1033	970	200	110
3818.50Y32075Y.9.HX	9	1143	1080	200	110
3818.50Y32075Y.10.HX	10	1253	1190	200	110
3818.50Y32075Y.11.HX	11	1363	1300	200	110
3818.50Y32075Y.12.HX	12	1473	1410	200	110

HEIGHT			WIDTH W mm	CONNECTION TYPES			
TOTAL HEIGHT H mm	LONG PORT HEIGHT H2 mm	SHORT PORT HEIGHT H3 mm		PRIMARY BSPM T1	PORT BSPM T2	PRIMARY	PORTS
278	235	85	85	1½"	¾"	Male Threaded	Male Threaded
278	235	85	85	1½"	¾"	Male Threaded	Male Threaded
278	235	85	85	1½"	¾"	Male Threaded	Male Threaded
278	235	85	85	1½"	¾"	Male Threaded	Male Threaded
278	235	85	85	1½"	¾"	Male Threaded	Male Threaded
278	235	85	85	1½"	¾"	Male Threaded	Male Threaded
278	235	85	85	1½"	¾"	Male Threaded	Male Threaded
278	235	85	85	1½"	¾"	Male Threaded	Male Threaded
278	235	85	85	1½"	¾"	Male Threaded	Male Threaded
278	235	85	85	1½"	¾"	Male Threaded	Male Threaded
278	235	85	85	1½"	¾"	Male Threaded	Male Threaded
278	235	85	85	1½"	¾"	Male Threaded	Male Threaded

## Manifolds (continued)

### Manifolds - Vertical with drain cock

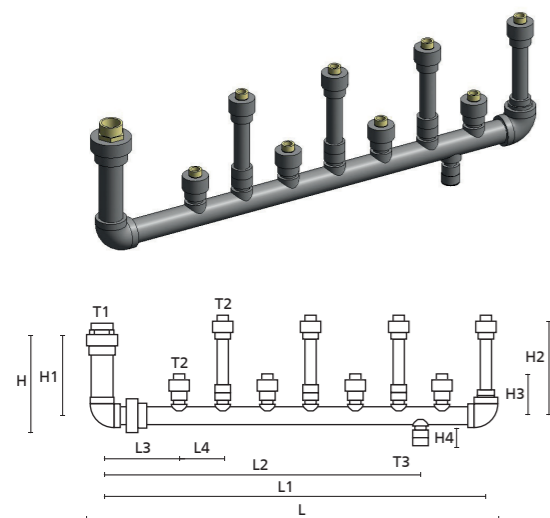

MANIFOLDS	NO. OF PORTS	LENGTH				
		TOTAL LENGTH L mm	TOTAL LENGTH (CENTRE) L1 mm	LENGTH TO DRAIN COCK L2 mm	LENGTH TO FIRST PORT L3 mm	LENGTH BETWEEN PORTS L4 mm
3808.50Y32075Y.2.VDX	2	440	365	200	255	110
3808.50Y32075Y.3.VDX	3	495	420	255	200	110
3808.50Y32075Y.4.VDX	4	605	530	365	200	110
3808.50Y32075Y.5.VDX	5	715	640	475	200	110
3808.50Y32075Y.6.VDX	6	825	750	585	200	110
3808.50Y32075Y.7.VDX	7	935	860	695	200	110
3808.50Y32075Y.8.VDX	8	1045	970	805	200	110
3808.50Y32075Y.9.VDX	9	1155	1080	915	200	110
3808.50Y32075Y.10.VDX	10	1265	1190	1025	200	110
3808.50Y32075Y.11.VDX	11	1375	1300	1135	200	110
3808.50Y32075Y.12.VDX	12	1485	1410	1245	200	110

## Manifolds (continued)

TOTAL HEIGHT H mm	HEIGHT				TOTAL WIDTH W mm	CONNECTION TYPES					
	VERTICAL INLET HEIGHT H1 mm	LONG PORT HEIGHT H2 mm	SHORT PORT HEIGHT H4 mm	DRAIN COCK HEIGHT H3 mm		PRIMARY BSPM T1	PORT BSPM T2	DRAIN BSPF T3	PRIMARY	PORTS	DRAIN
321	200	235	105	86	85	1½"	¾"	½"	Male Threaded	Male Threaded	Female Threaded
321	200	235	105	86	85	1½"	¾"	½"	Male Threaded	Male Threaded	Female Threaded
321	200	235	105	86	85	1½"	¾"	½"	Male Threaded	Male Threaded	Female Threaded
321	200	235	105	86	85	1½"	¾"	½"	Male Threaded	Male Threaded	Female Threaded
321	200	235	105	86	85	1½"	¾"	½"	Male Threaded	Male Threaded	Female Threaded
321	200	235	105	86	85	1½"	¾"	½"	Male Threaded	Male Threaded	Female Threaded
321	200	235	105	86	85	1½"	¾"	½"	Male Threaded	Male Threaded	Female Threaded
321	200	235	105	86	85	1½"	¾"	½"	Male Threaded	Male Threaded	Female Threaded
321	200	235	105	86	85	1½"	¾"	½"	Male Threaded	Male Threaded	Female Threaded
321	200	235	105	86	85	1½"	¾"	½"	Male Threaded	Male Threaded	Female Threaded
321	200	235	105	86	85	1½"	¾"	½"	Male Threaded	Male Threaded	Female Threaded
321	200	235	105	86	85	1½"	¾"	½"	Male Threaded	Male Threaded	Female Threaded

### Manifolds - Vertical with drain cock

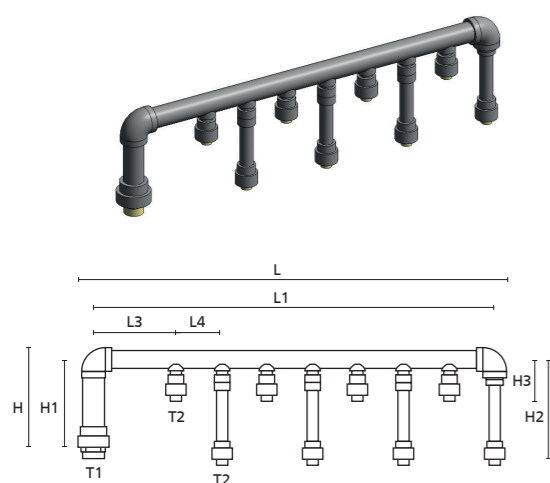

MANIFOLDS	NO. OF PORTS	LENGTH			
		TOTAL LENGTH L mm	TOTAL LENGTH (CENTRE) L1 mm	LENGTH TO FIRST PORT L3 mm	LENGTH BETWEEN PORTS L4 mm
3818.50Y32075Y.2.VX	2	385	310	200	110
3818.50Y32075Y.3.VX	3	495	420	200	110
3818.50Y32075Y.4.VX	4	605	530	200	110
3818.50Y32075Y.5.VX	5	715	640	200	110
3818.50Y32075Y.6.VX	6	825	750	200	110
3818.50Y32075Y.7.VX	7	935	860	200	110
3818.50Y32075Y.8.VX	8	1045	970	200	110
3818.50Y32075Y.9.VX	9	1155	1080	200	110
3818.50Y32075Y.10.VX	10	1265	1190	200	110
3818.50Y32075Y.11.VX	11	1375	1300	200	110
3818.50Y32075Y.12.VX	12	1485	1410	200	110

TOTAL HEIGHT H mm	HEIGHT				TOTAL WIDTH W mm	CONNECTION TYPES			
	VERTICAL INLET HEIGHT H1 mm	LONG PORT HEIGHT H2 mm	SHORT PORT HEIGHT H4 mm	DRAIN COCK HEIGHT H3 mm		PRIMARY BSPM T1	PORT BSPM T2	PRIMARY	PORTS
275	200	235	85	85	85	1½"	¾"	Male Threaded	Male Threaded
275	200	235	85	85	85	1½"	¾"	Male Threaded	Male Threaded
275	200	235	85	85	85	1½"	¾"	Male Threaded	Male Threaded
275	200	235	85	85	85	1½"	¾"	Male Threaded	Male Threaded
275	200	235	85	85	85	1½"	¾"	Male Threaded	Male Threaded
275	200	235	85	85	85	1½"	¾"	Male Threaded	Male Threaded
275	200	235	85	85	85	1½"	¾"	Male Threaded	Male Threaded
275	200	235	85	85	85	1½"	¾"	Male Threaded	Male Threaded
275	200	235	85	85	85	1½"	¾"	Male Threaded	Male Threaded
275	200	235	85	85	85	1½"	¾"	Male Threaded	Male Threaded
275	200	235	85	85	85	1½"	¾"	Male Threaded	Male Threaded
275	200	235	85	85	85	1½"	¾"	Male Threaded	Male Threaded

## Pipe and fittings

### Plain Ended Pipe

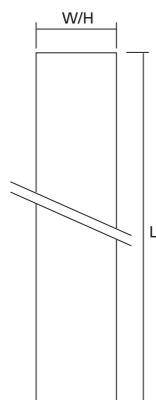

PIPE CODE	WIDTH W mm	LENGTH L mm	HEIGHT H mm	CONNECTION TYPES			
				PRIMARY DN D1 mm	SECONDARY DN D2 mm	PRIMARY	SECONDARY
3000.3.20.40G	20	4000	20	20	20	Spigot	Spigot
3000.3.25.40G	25	4000	25	25	25	Spigot	Spigot
3000.3.32.40G	32	4000	32	32	32	Spigot	Spigot
3000.5.40.40G	40	4000	40	40	40	Spigot	Spigot
3000.5.50.40G	50	4000	50	50	50	Spigot	Spigot
3000.5.63.40G	63	4000	63	63	63	Spigot	Spigot
3000.5.75.40G	75	4000	75	75	75	Spigot	Spigot
3000.5.90.40G	90	4000	90	90	90	Spigot	Spigot
3000.5.110.40G	110	4000	110	110	110	Spigot	Spigot
3000.5.125.58G	125	5800	125	125	125	Spigot	Spigot
3000.5.160.58G	160	5800	160	160	160	Spigot	Spigot
3000.5.200.58G	200	5800	200	200	200	Spigot	Spigot
3000.5.250.58G	250	5800	250	250	250	Spigot	Spigot
3000.5.315.58G	315	5800	315	315	315	Spigot	Spigot

### Electrofusion Coupling

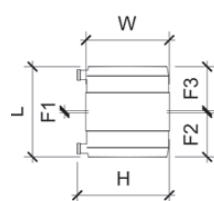
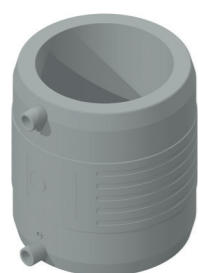

COUPLING CODE	WIDTH W mm	LENGTH L mm	HEIGHT H mm	FITTED LENGTH			CONNECTION TYPES	
				FITTED LENGTH F1 mm	FITTED LENGTH F2 mm	FITTED LENGTH F3 mm	PRIMARY DN D1 mm	SECONDARY DN D2 mm
3010.20G	35	77	52	3	37	37	20	20
3010.25G	42	74	59	2	36	36	25	25
3010.32G	49	82	82	2	40	40	32	32
3010.40G	58	85	85	3	41	41	40	40
3010.50G	72	102	87	4	49	49	50	50
3010.63G	86	118	101	2	58	58	63	63
3010.75G	106	130	119	4	64	64	75	75
3010.90G	123	145	131	3	71	71	90	90
3010.110G	149	160	163	2	79	79	110	110
3010.125G	164	183	177	3	90	90	125	125
3010.160G	210	191	223	4	94	94	160	160
3010.200G	248	213	252	7	103	103	200	200
3010.250G	318	246	321	6	120	120	250	250
3010.315G	393	290	384	4	143	143	315	315

## Pipe and fittings (continued)

### Double Socket

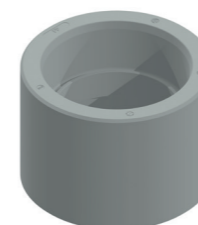

PIPE CODE	WIDTH W mm	LENGTH L mm	HEIGHT H mm	CONNECTION TYPES			
				PRIMARY DN D1 mm	SECONDARY DN D2 mm	PRIMARY	SECONDARY
3011S.20G	28	33	28	20	20	Socket	Socket
3011S.25G	35	37	35	25	25	Socket	Socket
3011S.32G	45	42	45	32	32	Socket	Socket
3011S.40G	55	46	55	40	40	Socket	Socket
3011S.50G	68	53	68	50	50	Socket	Socket
3011S.63G	84	63	84	63	63	Socket	Socket
3011S.75G	101	68	101	75	75	Socket	Socket
3011S.90G	117	72	117	90	90	Socket	Socket
3011S.110G	143	99	143	110	110	Socket	Socket
3011S.125G	162	90	162	125	125	Socket	Socket

### Elbow - 45° Socket

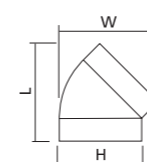
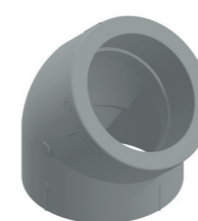

45° ELBOW CODE	WIDTH W mm	LENGTH L mm	HEIGHT H mm	CONNECTION TYPES			
				PRIMARY DN D1 mm	SECONDARY DN D2 mm	PRIMARY	SECONDARY
3001S.20.45G	39	46	28	20	20	Socket	Socket
3001S.25.45G	45	51	34	25	25	Socket	Socket
3001S.32.45G	56	62	42	32	32	Socket	Socket
3001S.40.45G	67	73	52	40	40	Socket	Socket
3001S.50.45G	81	85	65	50	50	Socket	Socket
3001S.63.45G	98	96	82	63	63	Socket	Socket
3001S.75.45G	121	122	101	75	75	Socket	Socket
3001S.90.45G	140	143	119	90	90	Socket	Socket
3001S.110.45G	168	172	144	110	110	Socket	Socket
3001S.125.45G	194	194	161	125	125	Socket	Socket
3001B.5.160.45G	207	220	166	160	160	Spigot	Spigot
3001B.5.200.45G	309	403	200	200	200	Spigot	Spigot
3001B.5.250.45G	390	513	250	250	250	Spigot	Spigot
3001B.5.315.45G	474	607	315	315	315	Spigot	Spigot

## Pipe and fittings (continued)

### Elbow - 90° Socket

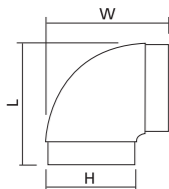
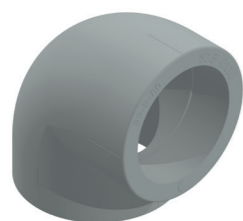

90° ELBOW	WIDTH	LENGTH	HEIGHT	CONNECTION TYPES			
				CODE	TOTAL WIDTH W mm	TOTAL LENGTH L mm	TOTAL HEIGHT H mm
3001S.20.90G	40	40	28	20	20	Socket	Socket
3001S.25.90G	47	47	35	25	25	Socket	Socket
3001S.32.90G	56	56	42	32	32	Socket	Socket
3001S.40.90G	68	68	52	40	40	Socket	Socket
3001S.50.90G	80	80	65	50	50	Socket	Socket
3001S.63.90G	100	100	82	63	63	Socket	Socket
3001S.75.90G	120	120	101	75	75	Socket	Socket
3001S.90.90G	145	145	119	90	90	Socket	Socket
3001S.110.90G	175	175	144	110	110	Socket	Socket
3001S.125.90G	213	213	161	125	125	Socket	Socket
3001B.5.160.90G	227	227	163	160	160	Spigot	Spigot
3001B.5.200.90G	420	420	200	200	200	Spigot	Spigot
3001B.5.250.90G	534	534	250	250	250	Spigot	Spigot
3001B.5.315.90G	639	639	315	315	315	Spigot	Spigot

### Tee - Socket

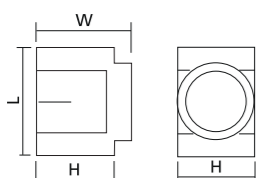
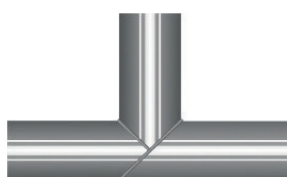
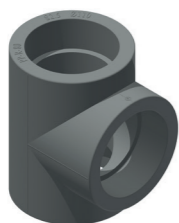

TEE	WIDTH	LENGTH	HEIGHT	CONNECTION TYPES					
				CODE	TOTAL WIDTH W mm	TOTAL LENGTH L mm	TOTAL HEIGHT H mm	PRIMARY DN D1 mm	BRANCH DN D2 mm
3004S.20.90G	41	52	29	20	20	20	Socket	Socket	Socket
3004S.25.90G	46	60	34	25	25	25	Socket	Socket	Socket
3004S.32.90G	58	73	43	32	32	32	Socket	Socket	Socket
3004S.40.90G	68	80	53	40	40	40	Socket	Socket	Socket
3004S.50.90G	83	99	66	50	50	50	Socket	Socket	Socket
3004S.63.90G	104	125	85	63	63	63	Socket	Socket	Socket
3004S.75.90G	120	139	101	75	75	75	Socket	Socket	Socket
3004S.90.90G	142	164	120	90	90	90	Socket	Socket	Socket
3004S.110.90G	172	200	144	110	110	110	Socket	Socket	Socket
3004S.125.90G	193	222	163	125	125	125	Socket	Socket	Socket
3004B.5.160.90G	232	297	166	160	160	160	Spigot	Spigot	Spigot
3004B.5.200.90G	330	460	200	200	200	200	Spigot	Spigot	Spigot
3004B.5.250.90G	390	530	250	250	250	250	Spigot	Spigot	Spigot
3004B.5.315.90G	475	635	315	315	315	315	Spigot	Spigot	Spigot

Dimensions given are subject to tolerance of +2mm

## Pipe and fittings (continued)

### Tee Reducing - Socket

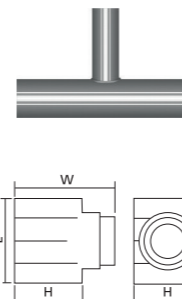

TEE REDUCING	WIDTH	LENGTH	HEIGHT	CONNECTION TYPES					
				CODE	TOTAL WIDTH W mm	TOTAL LENGTH L mm	TOTAL HEIGHT H mm	PRIMARY DN D1 mm	BRANCH DN D2 mm
3004S.25X20X25.90G	46	58	34	25	20	25	Socket	Socket	Socket
3004S.32X20X32.90G	54	56	43	32	20	32	Socket	Socket	Socket
3004S.32X25X32.90G	55	60	43	32	25	32	Socket	Socket	Socket
3004S.40X20X40.90G	64	83	52	40	20	40	Socket	Socket	Socket
3004S.40X25X40.90G	67	83	52	40	25	40	Socket	Socket	Socket
3004S.40X32X40.90G	68	84	53	40	32	40	Socket	Socket	Socket
3004S.50X25X50.90G	75	75	66	50	25	50	Socket	Socket	Socket
3004S.50X32X50.90G	78	90	67	50	32	50	Socket	Socket	Socket
3004S.50X40X50.90G	80	90	67	50	40	50	Socket	Socket	Socket
3004S.63X32X63.90G	93	90	85	63	32	63	Socket	Socket	Socket
3004S.63X40X63.90G	97	108	85	63	40	63	Socket	Socket	Socket
3004S.63X50X63.90G	98	108	85	63	50	63	Socket	Socket	Socket
3004S.75X32X75.90G	155	132	101	75	32	75	Socket	Socket	Socket
3004S.75X40X75.90G	155	132	101	75	40	75	Socket	Socket	Socket
3004S.75X50X75.90G	117	117	101	75	50	75	Socket	Socket	Socket
3004S.75X63X75.90G	119	132	101	75	63	75	Socket	Socket	Socket
3004S.90X50X90.90G	179	155	120	90	50	90	Socket	Socket	Socket
3004S.90X63X90.90G	139	155	120	90	63	90	Socket	Socket	Socket
3004S.90X75X90.90G	139	155	120	90	75	90	Socket	Socket	Socket
3004S.110X63X110.90G	209	180	144	110	63	110	Socket	Socket	Socket
3004S.110X75X110.90G	214	180	144	110	75	110	Socket	Socket	Socket
3004S.110X90X110.90G	167	180	144	110	90	110	Socket	Socket	Socket
3004B.5.160X110X160.90G	300	350	160	160	110	160	Spigot	Spigot	Spigot
3004B.5.160X125X160.90G	240	350	160	160	125	160	Spigot	Spigot	Spigot
3004B.5.200X125X200.90G	280	440	200	200	125	200	Spigot	Spigot	Spigot
3004B.5.200X160X200.90G	460	460	200	200	160	200	Spigot	Spigot	Spigot
3004B.5.250X160X250.90G	510	530	250	250	160	250	Spigot	Spigot	Spigot
3004B.5.250X200X250.90G	510	530	250	250	200	250	Spigot	Spigot	Spigot
3004B.5.315X160X315.90G	415	450	315	315	160	315	Spigot	Spigot	Spigot
3004B.5.315X200X315.90G	435	500	315	315	200	315	Spigot	Spigot	Spigot

## Pipe and fittings (continued)

### Reducer - Concentric

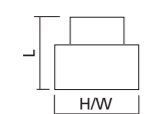
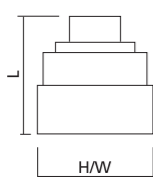
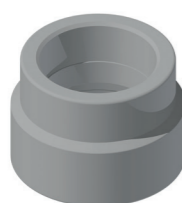

REDUCER CODE	WIDTH W mm	LENGTH L mm	HEIGHT H mm	CONNECTION TYPES			
				PRIMARY DN D1 mm	SECONDARY DN D2 mm	PRIMARY	SECONDARY
3024S.25X20G	28	34	28	25	20	Spigot	Socket
3024S.32X20G	32	36	32	32	20	Spigot	Socket
3024S.32X25G	33	36	33	32	25	Spigot	Socket
3024S.40X25G	40	40	40	40	25	Spigot	Socket
3024S.40X32G	40	50	40	40	32	Spigot	Socket
3024S.50X32G	50	40	50	50	32	Spigot	Socket
3024S.50X40G	50	48	50	50	40	Spigot	Socket
3024S.63X32G	63	48	63	63	32	Spigot	Socket
3024S.63X40G	63	64	63	63	40	Spigot	Socket
3024S.63X50G	63	64	63	63	50	Spigot	Socket
3024S.75X32G	75	65	75	75	32	Spigot	Socket
3024S.75X40G	75	65	75	75	40	Spigot	Socket
3024S.75X50G	75	65	75	75	50	Spigot	Socket
3024S.75X63G	75	65	75	75	63	Spigot	Socket
3024S.90X63G	90	71	90	90	63	Spigot	Socket
3024S.90X75G	90	79	90	90	75	Spigot	Socket
3024S.110X50G	110	112	110	110	50	Spigot	Socket
3024S.110X63G	110	73	110	110	63	Spigot	Socket
3024S.110X75G	110	78	110	110	75	Spigot	Socket
3024S.110X90G	110	94	110	110	90	Spigot	Socket
3024S.125X50G	125	193	125	125	50	Spigot	Socket
3024S.125X110G	125	112	125	125	110	Spigot	Socket
3024S.160X110G	160	88	160	160	110	Spigot	Socket
3024S.160X125G	160	90	160	160	125	Spigot	Socket
3024B.5.200X110G	200	435	200	200	110	Spigot	Spigot
3024B.5.200X125G	200	435	200	200	125	Spigot	Spigot
3024B.5.200X160G	200	365	200	200	160	Spigot	Spigot
3024B.5.250X160G	250	315	250	250	160	Spigot	Spigot
3024B.5.250X200G	250	440	250	250	200	Spigot	Spigot
3024B.5.315X200G	315	480	315	315	200	Spigot	Spigot
3024B.5.315X250G	315	531	315	315	250	Spigot	Spigot

## Pipe and fittings (continued)

### Threaded Adaptor - Transition piece, female thread

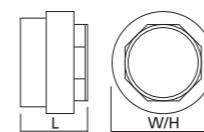
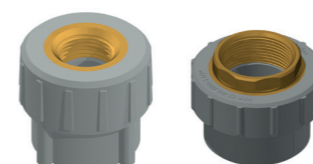

### Threaded Adaptor - Transition piece, male thread

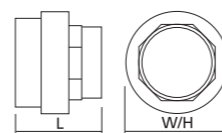
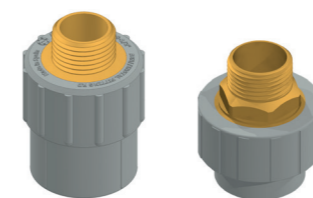

### Threaded Adaptor - Elbow, female thread

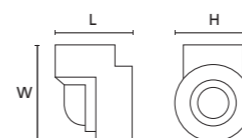
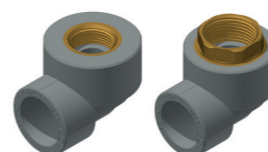

THREADED ADAPTOR CODE	WIDTH W mm	LENGTH L mm	HEIGHT H mm	CONNECTION TYPES			
				PRIMARY DN D1 mm	SECONDARY DN D2 mm	PRIMARY	SECONDARY
3016S.20X05G	39	44	39	20	½"	Socket	Female Thread
3016S.25X05G	37	41	37	25	½"	Socket	Female Thread
3016S.32X075G	42	40	42	32	¾"	Socket	Female Thread
3016S.32X075G	53	46	53	32	¾"	Socket	Female Thread
3016S.32X1G	58	52	58	32	1"	Socket	Female Thread HEX
3016S.40X125G	74	65	74	40	1¼"	Socket	Female Thread HEX
3016S.50X15G	86	66	86	50	1½"	Socket	Female Thread HEX
3016S.63X2G	100	87	100	63	2"	Socket	Female Thread HEX
3016S.75X25G	120	92	120	75	2½"	Socket	Female Thread HEX
3016S.90X3G	133	99	133	90	3"	Socket	Female Thread HEX
3016S.110X4G	155	100	155	110	4"	Socket	Female Thread HEX

THREADED ADAPTOR CODE	WIDTH W mm	LENGTH L mm	HEIGHT H mm	CONNECTION TYPES			
				PRIMARY DN D1 mm	SECONDARY DN D2 mm	PRIMARY	SECONDARY
3017S.20X05G	42	54	42	20	½"	Socket	Male Thread
3017S.25X05G	39	56	39	25	½"	Socket	Male Thread
3017S.32X075G	46	58	46	25	¾"	Socket	Male Thread
3017S.32X075G	49	60	49	32	¾"	Socket	Male Thread
3017S.32X1G	57	66	57	32	1"	Socket	Male Thread HEX
3017S.40X125G	72	82	72	40	1¼"	Socket	Male Thread HEX
3017S.50X15G	85	85	85	50	1"	Socket	Male Thread HEX
3017S.63X2G	100	102	100	63	2"	Socket	Male Thread HEX
3017S.75X25G	120	105	120	75	2½"	Socket	Male Thread HEX
3017S.90X3G	133	127	133	90	3"	Socket	Male Thread HEX
3017S.110X4G	158	133	158	110	4"	Socket	Male Thread HEX

THREADED ADAPTOR CODE	WIDTH W mm	LENGTH L mm	HEIGHT H mm	CONNECTION TYPES			
				PRIMARY DN D1 mm	SECONDARY DN D2 mm	PRIMARY	SECONDARY
3016S.32X075.90G	72	58	56	32	¾"	Socket	Female Thread
3016S.32X1.90G	72	69	57	32	1"	Socket	Female Thread HEX

## Pipe and fittings (continued)

### Threaded Adaptor - Elbow, male thread

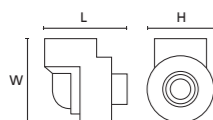
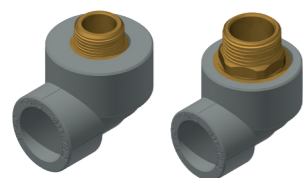

THREADED ADAPTOR	WIDTH	LENGTH	HEIGHT	CONNECTION TYPES			
				CODE	TOTAL WIDTH W mm	TOTAL LENGTH L mm	TOTAL HEIGHT H mm
3017S.32X075.90G	72	71	57	32	3/4"	Socket	Female Thread
3017S.32X1.90G	72	82	57	32	1"	Socket	Female Thread HEX

### Threaded Adaptor - Adaptor union, female thread

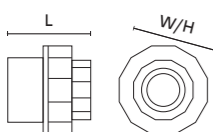
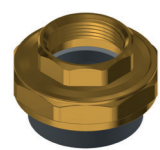

THREADED ADAPTOR	WIDTH	LENGTH	HEIGHT	CONNECTION TYPES			
				CODE	TOTAL WIDTH W mm	TOTAL LENGTH L mm	TOTAL HEIGHT H mm
3058S.20X05G	38	35	38	20	1/2"	Socket	Female Union Thread
3058S.25X075G	48	38	48	25	3/4"	Socket	Female Union Thread
3058S.32X1G	54	46	54	32	1"	Socket	Female Union Thread
3058S.40X125G	66	47	66	40	1 1/4"	Socket	Female Union Thread
3058S.50X15G	84	51	84	50	1 1/2"	Socket	Female Union Thread
3058S.63X2G	105	64	105	63	2"	Socket	Female Union Thread
3058S.75X25G	126	79	126	75	2 1/2"	Socket	Female Union Thread
3058S.90X3G	155	81	155	90	3"	Socket	Female Union Thread
3058S.110X4G	172	92	172	110	4"	Socket	Female Union Thread

### Threaded Adaptor - Adaptor union, male thread

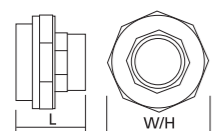
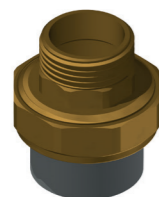

THREADED ADAPTOR	WIDTH	LENGTH	HEIGHT	CONNECTION TYPES			
				CODE	TOTAL WIDTH W mm	TOTAL LENGTH L mm	TOTAL HEIGHT H mm
3057S.20X05G	38	42	38	20	1/2"	Socket	Male Union Thread
3057S.25X075G	48	47	48	25	3/4"	Socket	Male Union Thread
3057S.32X1G	54	57	54	32	1"	Socket	Male Union Thread
3057S.40X125G	66	58	66	40	1 1/4"	Socket	Male Union Thread
3057S.50X15G	84	65	84	50	1 1/2"	Socket	Male Union Thread
3057S.63X2G	103	79	103	63	2"	Socket	Male Union Thread
3057S.75X25G	128	99	128	75	2 1/2"	Socket	Male Union Thread
3057S.90X3G	155	99	155	90	3"	Socket	Male Union Thread
3057S.110X4G	181	120	181	110	4"	Socket	Male Union Thread

## Pipe and fittings (continued)

### Threaded Adaptor - Female adaptor, loose nut

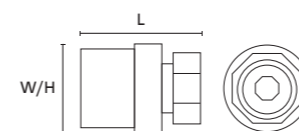

THREADED ADAPTOR	WIDTH	LENGTH	HEIGHT	CONNECTION TYPES			
				CODE	TOTAL WIDTH W mm	TOTAL LENGTH L mm	TOTAL HEIGHT H mm
3019S.32X1G	46	65	46	32	1"	Socket	Female Union Nut
3019S.32X125G	48	66	48	32	1 1/4"	Socket	Female Union Nut

### End Cap



END CAP	WIDTH	LENGTH	HEIGHT	CONNECTION TYPES	
				CODE	TOTAL WIDTH W mm
3030S.20G	29	26	29	20	Socket
3030S.25G	34	26	34	25	Socket
3030S.32G	43	30	43	32	Socket
3030S.40G	52	34	52	40	Socket
3030S.50G	65	40	65	50	Socket
3030S.63G	81	40	81	63	Socket
3030S.75G	100	50	100	75	Socket
3030S.90G	119	60	119	90	Socket
3030S.110G	150	68	150	110	Socket
3030S.125G	162	74	162	125	Socket
3030B.5.160G	165	223	165	160	Spigot
3030B.5.200G	206	273	206	200	Spigot
3030B.5.250G	256	284	256	250	Spigot
3030B.5.315G	318	278	318	315	Spigot

## Pipe and fittings (continued)

### Saddle



SADDLE CODE	WIDTH W mm	LENGTH L mm	HEIGHT H mm	CONNECTION TYPES			
				PRIMARY DN D1 mm	SECONDARY DN D2 mm	PRIMARY	SECONDARY
3054.50X20G	45	47	45	50	20	Saddle	Spigot
3054.50X25G	45	47	45	50	25	Saddle	Spigot
3054.50X32G	45	47	45	50	32	Saddle	Spigot
3054.63X20G	45	43	45	63	20	Saddle	Spigot
3054.63X25G	45	43	45	63	25	Saddle	Spigot
3054.63X32G	45	43	45	63	32	Saddle	Spigot
3054.75X20G	45	43	45	75	20	Saddle	Spigot
3054.75X25G	45	42	45	75	25	Saddle	Spigot
3054.75X32G	45	41	45	75	32	Saddle	Spigot
3054.90X20G	45	42	45	90	20	Saddle	Spigot
3054.90X25G	45	42	45	90	25	Saddle	Spigot
3054.90X32G	45	40	45	90	32	Saddle	Spigot
3054.90X40G	65	57	65	90	40	Saddle	Spigot
3054.90X50G	65	59	65	90	50	Saddle	Spigot
3054.110X20G	45	45	45	110	20	Saddle	Spigot
3054.110X25G	45	44	45	110	25	Saddle	Spigot
3054.110X32G	45	43	45	110	32	Saddle	Spigot
3054.110X40G	65	59	65	110	40	Saddle	Spigot
3054.110X50G	65	60	65	110	50	Saddle	Spigot
3054.110X63G	82	74	82	110	63	Saddle	Spigot
3054.125X20G	45	44	45	125	20	Saddle	Spigot
3054.125X25G	45	44	45	125	25	Saddle	Spigot
3054.125X32G	45	43	45	125	32	Saddle	Spigot
3054.125X40G	65	59	65	125	40	Saddle	Spigot
3054.125X50G	65	60	65	125	50	Saddle	Spigot
3054.125X63G	82	80	82	125	63	Saddle	Spigot
3054.160X20G	45	47	45	160	20	Saddle	Spigot
3054.160X25G	45	43	45	160	25	Saddle	Spigot
3054.160X32G	45	46	45	160	32	Saddle	Spigot
3054.160X40G	65	61	65	160	40	Saddle	Spigot
3054.160X50G	65	61	65	160	50	Saddle	Spigot
3054.160X63G	82	81	82	160	63	Saddle	Spigot
3054.200X20G	45	47	45	200	20	Saddle	Spigot
3054.200X25G	45	47	45	200	25	Saddle	Spigot
3054.200X32G	45	47	45	200	32	Saddle	Spigot
3054.200X40G	65	64	65	200	40	Saddle	Spigot
3054.200X50G	65	64	65	200	50	Saddle	Spigot
3054.200X63G	82	84	82	200	63	Saddle	Spigot
3054.250X40G	65	64	65	250	40	Saddle	Spigot
3054.250X50G	65	67	65	250	50	Saddle	Spigot
3054.250X63G	82	82	82	250	63	Saddle	Spigot
3054.315X40G	65	67	65	315	40	Saddle	Spigot
3054.315X50G	65	67	65	315	50	Saddle	Spigot
3054.315X63G	82	83	82	315	63	Saddle	Spigot

## Pipe and fittings (continued)

### Stub Flange - PN16 & PN25



STUB FLANGE CODE	WIDTH W mm	LENGTH L mm	HEIGHT H mm	CONNECTION TYPES		
				PRIMARY DN D1 mm	PRIMARY	SECONDARY
3080S.40G	62	24	62	40	Socket	Flange
3080S.50G	89	31	89	50	Socket	Flange
3080S.63G	98	35	98	63	Socket	Flange
3080S.75G	116	35	116	75	Socket	Flange
3080S.90G	133	43	133	90	Socket	Flange
3080S.110G	157	52	157	110	Socket	Flange
3080S.125G	186	54	186	125	Socket	Flange
3080B.5.160G	220	193	220	160	Spigot	Flange
3080B.5.200G	270	272	270	200	Spigot	Flange
3080B.5.250G	319	282	319	250	Spigot	Flange
3080B.5.315G	-	-	-	315	Spigot	Flange

### Backing Ring - PN16

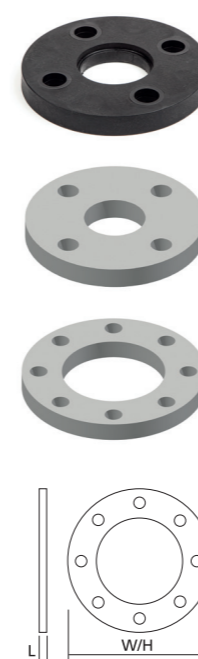

BACKING RING CODE	WIDTH W mm	LENGTH L mm	HEIGHT H mm	FIXINGS		
				PCD mm	HOLE COUNT	BOLT SIZE
3081.40S	140	6	140	100	4	M16
3081.50S	150	6	150	110	4	M16
3081.63S	165	8	165	125	4	M16
3081.75S	185	8	185	145	4	M16
3081.90S	200	8	200	160	8	M16
3081.110S	220	8	220	180	8	M16
3081.125S	250	10	250	210	8	M16
3081.160S	285	10	285	240	8	M20
3081.200S	340	10	340	295	12	M20
3081.250S	-	-	-	-	-	-
3081.315S	-	-	-	-	-	-

Pipe and fittings (continued)

Backing Ring - PN25

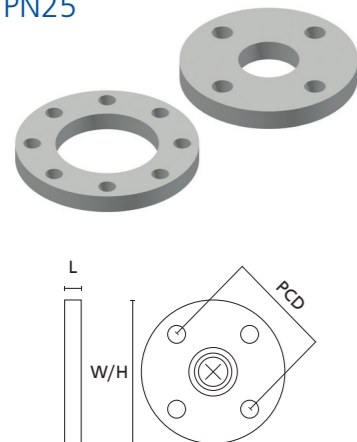

BACKING RING CODE	WIDTH			LENGTH			HEIGHT			FIXINGS		
	TOTAL WIDTH W mm	TOTAL LENGTH L mm	TOTAL HEIGHT H mm	PCD mm	HOLE COUNT	BOLT SIZE						
3081.40.25PN	150	18	150	110	4	M16						
3081.50.25PN	165	20	165	125	4	M16						
3081.63.25PN	185	22	185	145	8	M16						
3081.75.25PN	200	24	200	160	8	M16						
3081.90.25PN	200	24	200	160	8	M16						
3081.110.25PN	235	24	235	190	8	M20						
3081.125.25PN	270	26	270	220	8	M24						
3081.160.25PN	300	28	300	250	8	M24						
3081.200.25PN	360	32	360	310	12	M24						
3081.250.25PN	425	35	425	370	12	M27						
3081.315.25PN	485	38	485	430	16	M27						

Seal - PN16 & PN25



BACKING RING CODE	WIDTH			LENGTH			HEIGHT		
	TOTAL WIDTH W mm	TOTAL LENGTH L mm	TOTAL HEIGHT H mm						
3082.40B	61	3	61						
3082.50B	73	3	73						
3082.63B	90	3	90						
3082.75B	106	3	106						
3082.90B	125	3	125						
3082.110B	150	4	150						
3082.125B	188	4	188						
3082.160B	213	4	213						
3082.200B	254	4	254						
3082.250B	-	-	-						
3082.315B	-	-	-						

Blanking Flange - PN16

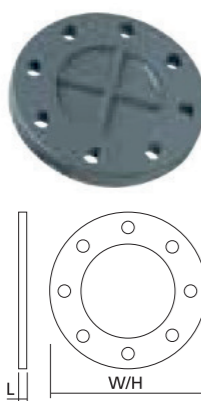

BACKING RING CODE	WIDTH			LENGTH			HEIGHT			FIXINGS		
	TOTAL WIDTH W mm	TOTAL LENGTH L mm	TOTAL HEIGHT H mm	PCD mm	HOLE COUNT	BOLT SIZE						
3083.40S	141	15	141	110	4	M16						
3083.50S	150	16	150	125	4	M16						
3083.63S	165	18	165	145	4	M16						
3083.75S	185	19	185	160	4	M16						
3083.90S	200	20	200	160	8	M16						
3083.110S	220	22	220	180	8	M16						
3083.125S	250	26	250	210	8	M16						
3083.160S	285	28	285	240	8	M20						
3081.200S	345	30	345	295	8	M20						
3081.250S	-	-	-	-	-	-						
3081.315S	-	-	-	-	-	-						

Pipe and fittings (continued)

Blanking Flange - PN25

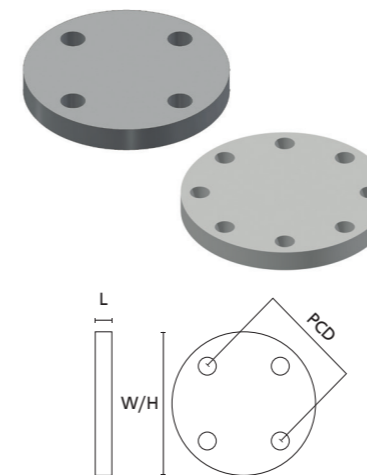

BACKING RING CODE	WIDTH			LENGTH			HEIGHT			FIXINGS		
	TOTAL WIDTH W mm	TOTAL LENGTH L mm	TOTAL HEIGHT H mm	PCD mm	HOLE COUNT	BOLT SIZE						
3083.40.25PN	150	18	150	110	4	M16						
3083.50.25PN	165	20	165	125	4	M16						
3083.63.25PN	185	22	185	145	8	M16						
3083.75.25PN	200	25	200	160	8	M16						
3083.90.25PN	200	24	200	160	8	M16						
3083.110.25PN	235	24	235	190	8	M20						
3083.125.25PN	270	26	270	220	8	M24						
3083.160.25PN	300	28	300	250	8	M24						
3083.200.25PN	360	32	360	310	12	M24						
3083.250.25PN	425	35	425	370	12	M27						
3083.315.25PN	485	38	485	430	16	M27						

Product Connections and Sizes

DIA mm	BSP CONNECTIONS AVAILABLE									BACKING RING PN16				BACKING RING PN25					
	1/2"	3/4"	1"	1 1/4"	1 1/2"	2"	2 1/2"	3"	4"	DRILLING/RATING	LENGTH L mm	PCD mm	HOLE COUNT	BOLT SIZE	DRILLING/RATING	LENGTH L mm	PCD mm	HOLE COUNT	BOLT SIZE
20	•									BS4504 PN10/16	-	-	-	-	BS4504 PN25/40	-	-	-	-
25	•	•								BS4504 PN10/16	-	-	-	-	BS4504 PN25/40	-	-	-	-
32		•	•	•						BS4504 PN10/16	-	-	-	-	BS4504 PN25/40	-	-	-	-
40				•						BS4504 PN10/16	6	140	4	M16	BS4504 PN25/40	18	110	4	M16
50					•					BS4504 PN10/16	6	150	4	M16	BS4504 PN25/40	20	125	4	M16
63						•				BS4504 PN10/16	8	165	4	M16	BS4504 PN25/40	22	145	8	M16
75							•			BS4504 PN10/16	8	185	4	M16	BS4504 PN25/40	24	160	8	M16
90								•		BS4504 PN10/16	8	200	8	M16	BS4504 PN25/40	24	160	8	M16
110									•	BS4504 PN10/16	8	220	8	M16	BS4504 PN25/40	24	190	8	M20
125										BS4504 PN10/16	10	250	8	M16	BS4504 PN25/40	26	220	8	M24
160										BS4504 PN10/16	10	285	8	M20	BS4504 PN25/40	28	250	8	M24
200										BS4504 PN10/16	10	340	12		BS4504 PN25/40	32	310	12	M24
250										BS4504 PN10/16	-	-	-		BS4504 PN25/40	35	370	12	M27
315										BS4504 PN10/16	-	-	-		BS4504 PN25/40	38	430	16	M27

\* Please check detailed product pages for Threaded Adaptor types available in each size.

# 4. System sizing

For successful, long-lasting system performance, system sizing is crucial.

A number of factors must be taken into account by the Design Engineer, and the system must be designed in accordance with design recommendations, including:

BS EN 1997 Geo-technical Design.

BS EN 806 Specifications for installations inside buildings conveying water for human consumption.

BS 8558 Guide to the design, installation, testing and maintenance of services supplying water for domestic use within buildings and their curtilages.

CIPHE Design Guide.

CIBSE Guide G - Public Health & Plumbing Engineering.

CIBSE Guide C Reference Data.

WRAS Water Regulation Guidelines.

The following section details the key parameters of the system that must be considered in order to complete a satisfactory design.



## Diameter equivalence – between MecFlow Fusion and copper pipes

QUICK EQUIVALENCE TABLE	
CU PIPE OD (mm)	MECFLOW FUSION PIPE OD (mm)
15	20
22	25
28	32
35	40
42	50
54	63
67	75
76	90
90	110
108	125
133	160
159	200
219	250

Table 4.01

NOTE: For accurate sizing please refer to MecFlow Fusion Temperature and Pressure ratings table on page 34, Table 4.08.

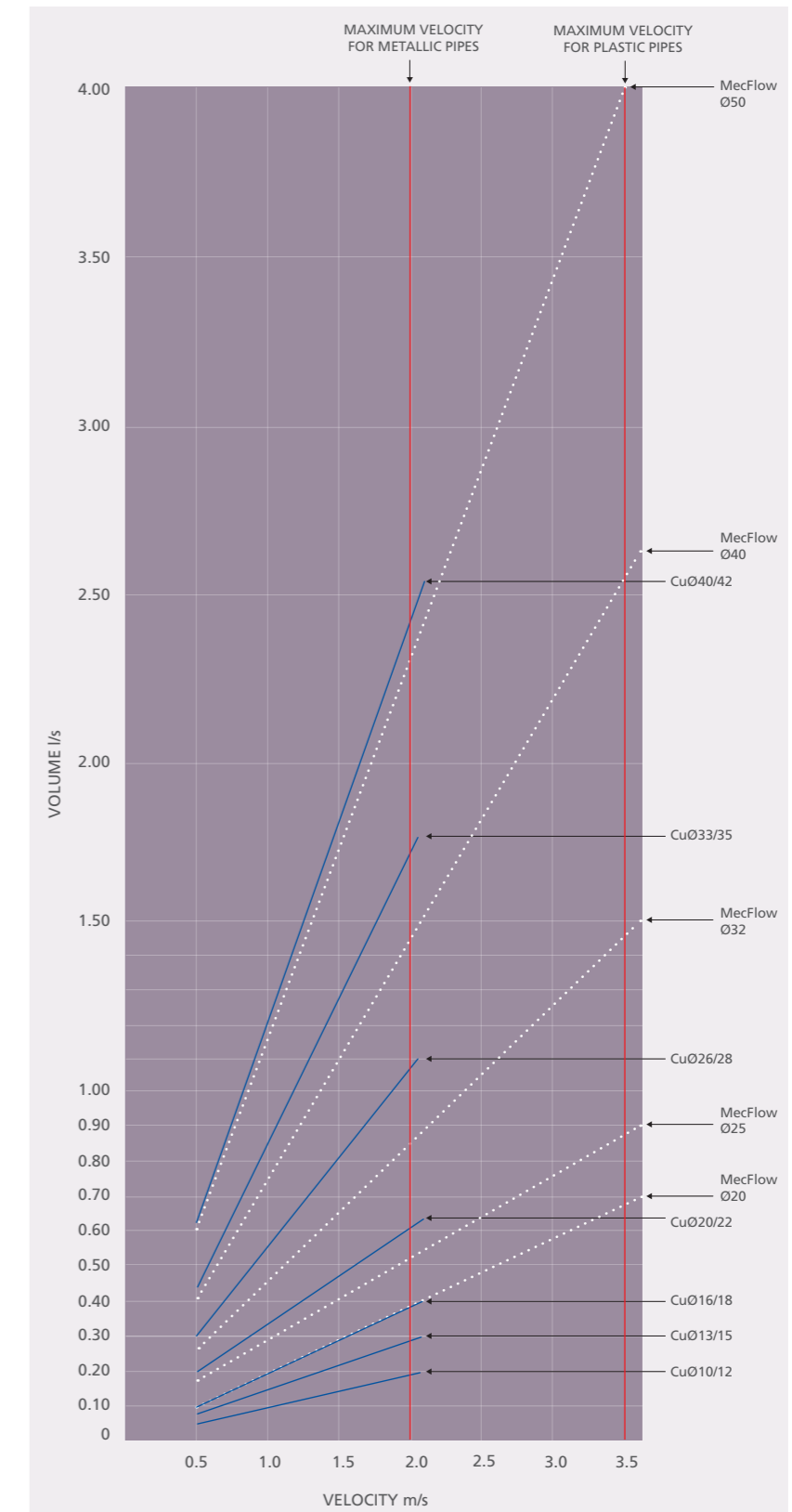

Graph 4.02

## Diameter equivalence – between MecFlow Fusion and steel pipes

QUICK EQUIVALENCE TABLE	
STEEL OD (inches)	MECFLOW FUSION OD (mm)
3/8	20
1/2	20
3/4	25
1	32
1 1/4	40
1 1/2	50
2	63
2 1/2	75
3	90
4	110
5	125
6	160
8	200
10	250
12	315

This table shows threaded steel, thin wall steel should follow the Copper table 4.01.

Table 4.03

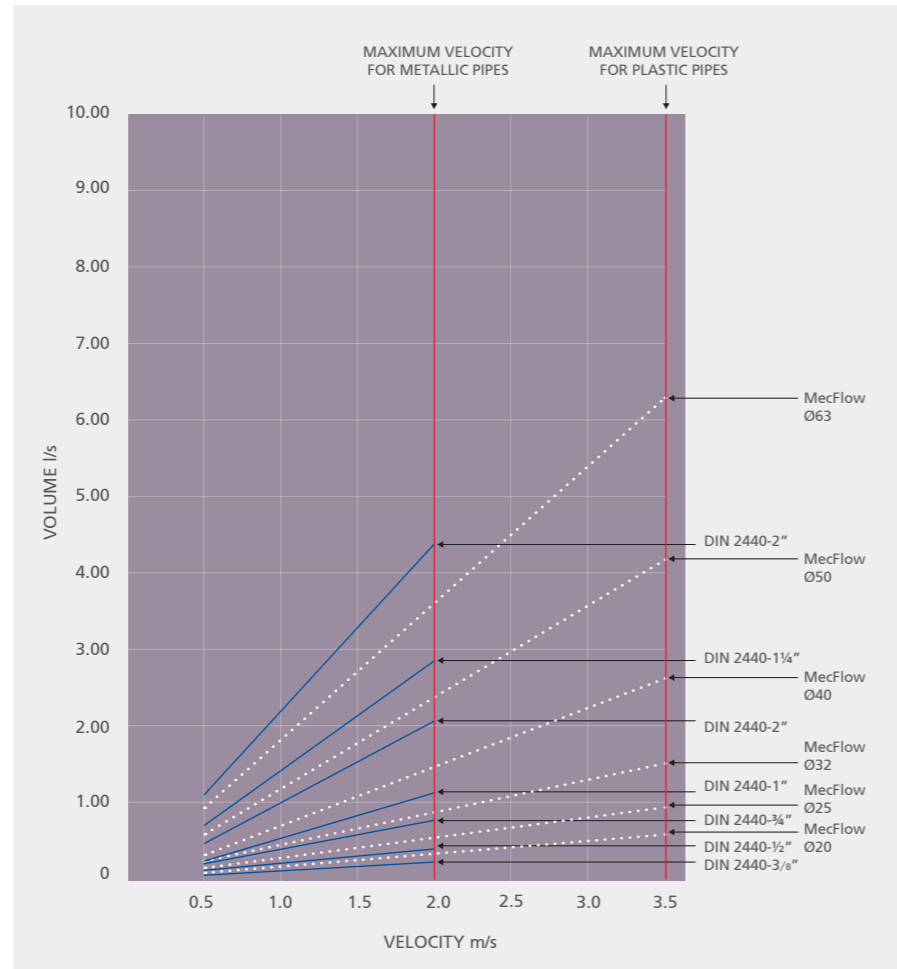

Graph 4.04

## Diameter equivalence – between MecFlow Fusion and steel pipes 75mm to 200mm

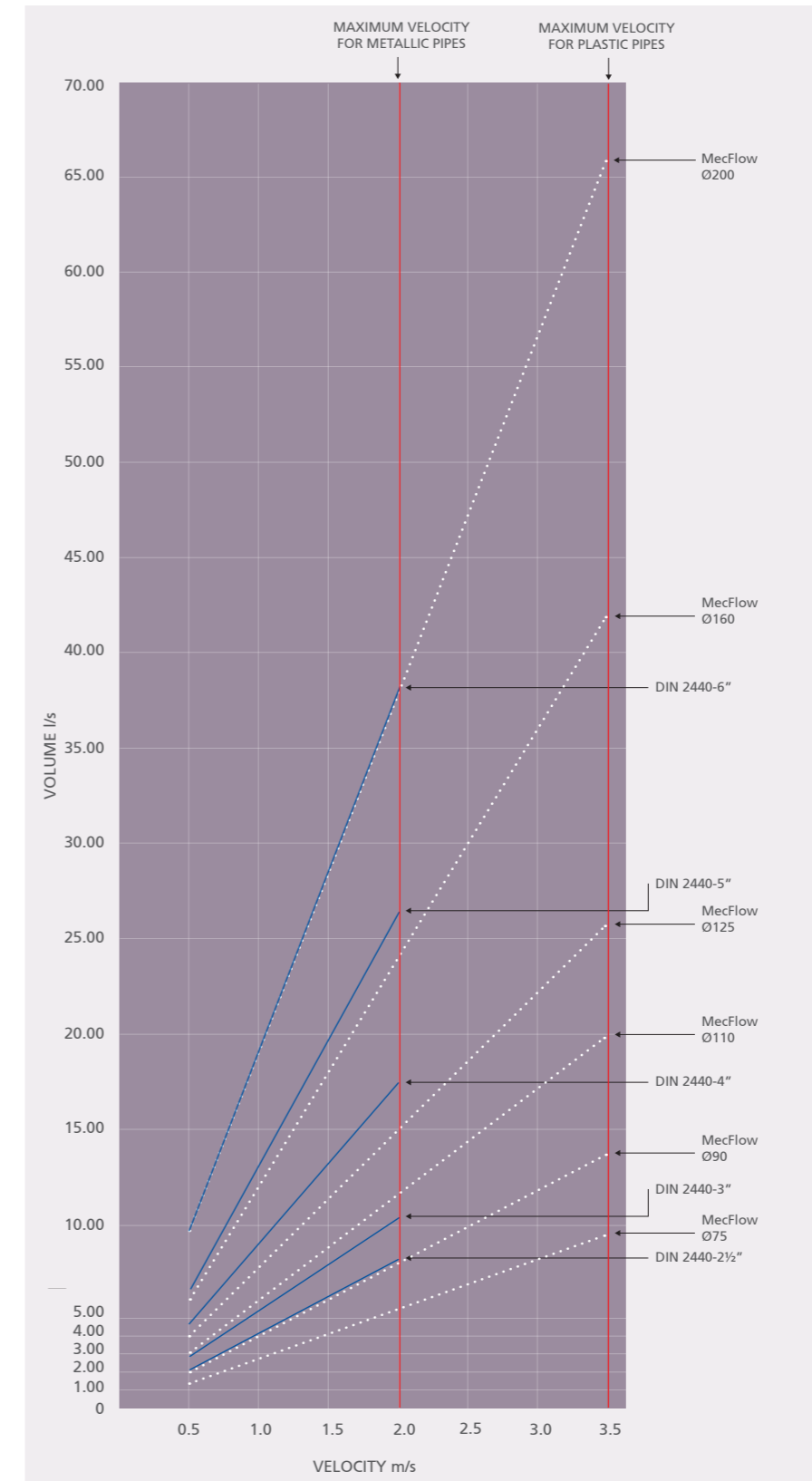

Graph 4.05

## Co-efficient of Loss ( $\phi$ ) – by product type















FITTING	PRODUCT IMAGE	SYMBOL	COMMENT	z-VALUE
Tee				0.25
			Separation of flow	0.25
			Conjunction of flow	0.80
			Counter current in case of separation of flow	1.80
			Counter current in case of conjunction of flow	3.00
Tee in derivation				1.30
Tee in reduced derivation				0.30
Tee of influx				0.90
Tee of reduced influx				0.60

Table 4.06

→ = Flow direction

FITTING	PRODUCT IMAGE	SYMBOL	COMMENT	z-VALUE
Elbow 90°				1.13
Elbow with female thread				1.40
Elbow with male thread				1.60
Elbow 45°			Up to 160mm	0.50
Socket				0.25
Reducer large Ø to small Ø			Reduction by: 1 dimension 0.40 2 dimension 0.50 3 dimension 0.60 4 dimension 0.70 5 dimension 0.80 6 dimension 0.90	
Conic expansion			$\beta = 10^\circ$ 0.20 $\beta = 20^\circ$ 0.45 $\beta = 30^\circ$ 0.60 $\beta = 40^\circ$ 0.75	
Expansion with free unload				1.00
Transition piece with female thread				0.50
Transition piece with male thread				0.70

Table 4.07



## MecFlow Fusion Temperature and Pressure Ratings

TEMPERATURE	YEARS OF SERVICE	MECFLOW FUSION DIAMETERS 20 - 32MM		MECFLOW FUSION DIAMETERS 40 - 315mm	
		BAR	PSI	BAR	PSI
10°C	1	39.20	568.52	25.08	363.75
	5	38.20	554.04	24.40	353.89
	10	37.57	544.90	24.04	348.67
	25	36.75	533.01	23.52	341.12
	50	36.50	529.38	23.36	338.80
20°C	100	35.95	521.41	23.00	333.58
	1	34.15	495.30	21.85	316.90
	5	33.05	479.34	21.15	306.75
	10	32.77	474.70	20.97	304.14
	25	32.00	464.12	20.48	297.03
30°C	50	31.70	459.76	20.30	294.42
	100	31.10	451.79	19.93	289.06
	1	29.80	432.21	19.08	276.73
	5	29.00	420.60	18.56	269.19
	10	28.45	412.63	18.20	263.96
40°C	25	27.90	404.65	17.85	258.89
	50	27.62	400.59	17.68	256.42
	100	27.05	392.32	17.31	251.06
	1	26.05	377.82	16.67	241.77
	5	25.20	365.49	16.12	233.80
50°C	10	24.65	357.51	15.77	228.72
	25	24.37	353.45	15.60	226.25
	50	23.82	345.47	15.24	221.03
	100	23.52	341.12	15.05	218.28
	1	23.05	334.31	14.75	213.93
60°C	5	22.17	321.54	14.19	205.80
	10	21.60	313.28	13.82	200.44
	25	21.30	308.93	13.63	197.78
	50	20.75	300.95	13.20	191.44
	100	20.45	296.60	13.00	188.54
70°C	1	19.37	280.93	12.40	179.84
	5	18.80	272.67	12.03	174.48
	10	18.50	268.31	11.84	171.72
	25	17.92	259.90	11.47	166.35
	50	17.70	256.71	11.30	163.89
80°C	1	16.55	240.03	10.59	153.59
	5	15.67	227.27	10.00	145.03
	10	15.40	223.35	9.85	142.86
	25	15.10	219.00	9.66	140.10
	50	14.90	216.10	9.50	137.78
95°C	1	13.82	200.44	8.84	128.21
	5	13.22	191.73	8.46	122.70
	10	12.92	187.38	8.27	119.94
	25	12.70	184.19	8.10	117.48
	50	10.75	155.91	6.88	99.78
		10.15	147.21	6.49	94.12

Table 4.08

## MecFlow Fusion pressure loss tables

The following pressure loss tables can be used as a design guide. To identify the correct pressure loss value, follow these steps:

- Step 1**  
Look up the required flow system flow rate
- Step 2**  
Reference the design velocity
- Step 3**  
Identify the chosen diameter
- Step 4**  
Read the R-value - loss mbar/m

FLOW l/s		EXTERNAL DIAMETER mm		32	Step 3
		20	25	32	
		THICKNESS mm	2.8	3.5	4.4
		INTERNAL DIAMETER mm	14.4	18.0	23.2
		'R'- PRESSURE LOSS (mbar/m)	'V'- VELOCITY (m/s)		
0.32	R	32.86	11.21	3.33	Step 1
	V	1.96	1.26	0.76	
0.34	R	36.62	12.48	3.70	Step 1
	V	2.09	1.34	0.80	
0.36	R	40.56	13.80	4.09	Step 1
	V	2.21	1.41	0.85	
0.38	R	44.69	15.19	4.50	Step 1
	V	2.33	1.49	0.90	
0.40	R	49.00	16.64	4.92	Step 1
	V	2.46	1.57	0.95	
0.45	R	60.59	20.51	6.05	Step 1
	V	2.76	1.77	1.06	
0.50	R	73.32	24.76	7.28	Step 1
	V	3.07	1.96	1.18	
0.55	R	87.19	29.38	8.62	Step 1
	V	3.38	2.16	1.30	
0.60	R	102.18	34.35	10.06	Step 1
	V	3.68	2.36	1.42	
0.65	R		39.69	11.60	Step 1
	V		2.55	1.54	
0.70	R		45.38	13.13	Step 1
	V		2.75	1.66	
0.75	R		51.43	14.98	Step 1
	V		2.95	1.77	
0.80	R		57.84	16.81	Step 1
	V		3.14	1.89	
0.85	R		64.60	18.75	Step 1
	V		3.34	2.01	
0.90	R		71.71	20.78	Step 1
	V		3.54	2.13	
0.95	R			22.19	Step 1
	V			2.25	
1.00	R			25.13	Step 1
	V			2.37	
1.10	R			29.86	Step 1
	V			2.60	
1.20	R			34.98	Step 1
	V			2.84	
1.30	R			40.47	Step 1
	V			3.08	
1.40	R			46.34	Step 1
	V			3.31	
1.50	R			52.58	Step 1
	V			3.55	

Table 4.09

EXAMPLE

## MecFlow Fusion – pressure loss

FLOW l/s	EXTERNAL DIAMETER mm	2.0	25	32
	THICKNESS mm	2.8	3.5	4.4
	INTERNAL DIAMETER mm	14.4	18.0	23.2
	'R'– PRESSURE LOSS (mbar/m)	'V'– VELOCITY (m/s)		
0.01	R	0.10		
	V	0.60		
0.02	R	0.30	0.11	
	V	0.12	0.08	
0.03	R	0.58	0.21	
	V	0.18	0.12	
0.04	R	0.93	0.33	0.10
	V	0.25	0.16	0.09
0.05	R	1.34	0.47	0.15
	V	0.31	0.20	0.12
0.06	R	1.82	0.64	0.20
	V	0.37	0.24	0.14
0.07	R	2.36	0.83	0.25
	V	0.43	0.28	0.17
0.08	R	2.95	1.04	0.32
	V	0.49	0.31	0.19
0.09	R	3.61	1.26	0.38
	V	0.55	0.35	0.21
0.10	R	4.32	1.51	0.46
	V	0.61	0.39	0.24
0.11	R	5.08	1.77	0.54
	V	0.68	0.43	0.26
0.12	R	5.90	2.05	0.62
	V	0.74	0.47	0.28
0.13	R	6.77	2.35	0.71
	V	0.80	0.51	0.31
0.14	R	7.70	2.67	0.81
	V	0.86	0.55	0.33
0.15	R	8.67	3.00	0.91
	V	0.92	0.59	0.35
0.16	R	9.70	3.36	1.01
	V	0.98	0.63	0.38
0.17	R	10.78	3.73	1.12
	V	1.04	0.67	0.40
0.18	R	11.91	4.11	1.24
	V	1.11	0.71	0.43
0.19	R	13.09	4.51	1.36
	V	1.17	0.75	0.45
0.20	R	14.32	4.93	1.48
	V	1.23	0.79	0.47
0.22	R	16.93	5.82	1.74
	V	1.35	0.86	0.52
0.24	R	19.73	6.77	2.02
	V	1.47	0.94	0.57
0.26	R	22.73	7.79	2.32
	V	1.60	1.02	0.62
0.28	R	25.92	8.87	2.64
	V	1.72	1.10	0.66
0.30	R	29.29	10.01	2.98
	V	1.84	1.18	0.71

Table 4.10

FLOW l/s	EXTERNAL DIAMETER mm	2.0	25	32
	THICKNESS mm	2.8	3.5	4.4
	INTERNAL DIAMETER mm	14.4	18.0	23.2
	'R'– PRESSURE LOSS (mbar/m)	'V'– VELOCITY (m/s)		
0.32	R	32.86	11.21	3.33
	V	1.96	1.26	0.76
0.34	R	36.62	12.48	3.70
	V	2.09	1.34	0.80
0.36	R	40.56	13.80	4.09
	V	2.21	1.41	0.85
0.38	R	44.69	15.19	4.50
	V	2.33	1.49	0.90
0.40	R	49.00	16.64	4.92
	V	2.46	1.57	0.95
0.45	R	60.59	20.51	6.05
	V	2.76	1.77	1.06
0.50	R	73.32	24.76	7.28
	V	3.07	1.96	1.18
0.55	R	87.19	29.38	8.62
	V	3.38	2.16	1.30
0.60	R	102.18	34.35	10.06
	V	3.68	2.36	1.42
0.65	R		39.69	11.60
	V		2.55	1.54
0.70	R		45.38	13.24
	V		2.75	1.66
0.75	R		51.43	14.98
	V		2.95	1.77
0.80	R		57.84	16.81
	V		3.14	1.89
0.85	R		64.60	18.75
	V		3.34	2.01
0.90	R		71.71	20.78
	V		3.54	2.13
0.95	R			22.19
	V			2.25
1.00	R			25.13
	V			2.37
1.10	R			29.86
	V			2.60
1.20	R			34.98
	V			2.84
1.30	R			40.47
	V			3.08
1.40	R			46.34
	V			3.31
1.50	R			52.58
	V			3.55

Table 4.11

## MecFlow Fusion – pressure loss

FLOW l/s	EXTERNAL DIAMETER mm	40	50	63	75	90	110	125	160	200	250	315
	THICKNESS mm	3.7	4.6	5.8	6.8	8.2	10	11.4	14.6	18.2	22.7	28.6
	INTERNAL DIAMETER mm	32.6	40.8	51.4	61.4	73.6	90.0	102.2	130.8	163.6	204.6	257.8
	'R'– PRESSURE LOSS (mbar/m)	'V'– VELOCITY (m/s)										
0.10	R	0.09										
	V	0.12										
0.20	R	0.30	0.10									
	V	0.24	0.15									
0.30	R	0.59	0.21									
	V	0.36	0.23									
0.40	R	0.97	0.34									
	V	0.48	0.31									
0.50	R	1.43	0.49									
	V	0.60	0.38									
0.60	R	1.97	0.68	0.23								
	V	0.72	0.46	0.29								
0.70	R	2.58	0.88	0.30								
	V	0.84	0.54	0.34								
0.80	R	3.27	1.12	0.37								
	V	0.96	0.61	0.39								
0.90	R	4.02	1.37	0.46	0.20							
	V	1.08	0.69	0.43	0.30							
1.00	R	4.85	1.65	0.55	0.24							
	V	1.20	0.76	0.48	0.34							
1.10	R	5.74	1.95	0.65	0.28							
	V	1.32	0.84	0.53	0.37							
1.20	R	6.71	2.28	0.76	0.32							
	V	1.44	0.92	0.58	0.41							
1.30	R	7.75	2.63	0.87	0.37	0.16						
	V	1.56	0.99	0.63	0.44	0.31						
1.40	R	8.84	3.00	0.99	0.42	0.18						
	V	1.68	1.07	0.67	0.47	0.33						
1.50	R	10.01	3.39	1.12	0.48	0.20						
	V	1.80	1.15	0.72	0.51	0.35						
1.60	R	11.24	3.80	1.25	0.54	0.23						
	V	1.92	1.22	0.77	0.54	0.38						
1.70	R	12.54	4.23	1.39	0.60	0.25						
	V	2.04	1.30	0.82	0.57	0.40						
1.80	R	13.91	4.69	1.54	0.66	0.28						
	V	2.16	1.38	0.87	0.61	0.42						
1.90	R	15.34	5.17	1.70	0.72	0.30	0.12					
	V	2.28	1.45	0.92	0.64	0.45	0.30					
2.00	R	16.84	5.67	1.86	0.79	0.33	0.13					
	V	2.40	1.35	0.96	0.68	0.47	0.31					
2.20	R	20.02	6.72	2.20	0.94	0.39	0.15					
	V	2.64	1.68	1.06	0.74	0.52	0.35					
2.40	R	23.47	7.87	2.58	1.10	0.46	0.18					
	V	2.88	1.84	1.16	0.81	0.56	0.38					
2.60	R	27.17	9.09	2.97	1.26	0.53	0.20	0.11				
	V	3.11	1.99	1.25	0.88	0.61	0.41	0.32				
2.80	R	31.13	10.40	3.39	1.44	0.60	0.23	0.13				
	V	3.35	2.14	1.35	0.95	0.66	0.44	0.34				
3.00	R	35.34	11.79	3.84	1.63	0.68	0.26	0.14				
	V	3.59	2.29	1.45	1.01	0.71	0.47	0.37				

Table 4.12

## MecFlow Fusion – pressure loss

FLOW l/s	EXTERNAL DIAMETER mm	40	50	63	75	90	110	125	160	200	250	315
	THICKNESS mm	3.7	4.6	5.8	6.8	8.2	10	11.4	14.6	18.2	22.7	28.6
	INTERNAL DIAMETER mm	32.6	40.8	51.4	61.4	73.6	90.0	102.2	130.8	163.6	204.6	257.8
	'R'– PRESSURE LOSS (mbar/m)	'V'– VELOCITY (m/s)										
3.20	R		13.26	4.32	1.83	0.77	0.29	0.16				
	V		<b>2.45</b>	<b>1.54</b>	<b>1.08</b>	<b>0.75</b>	<b>0.50</b>	<b>0.39</b>				
3.40	R		14.81	4.81	2.04	0.85	0.33	0.18				
	V		<b>2.60</b>	<b>1.64</b>	<b>1.15</b>	<b>0.80</b>	<b>0.53</b>	<b>0.41</b>				
3.60	R		16.44	5.34	2.26	0.94	0.36	0.20				
	V		<b>2.75</b>	<b>1.73</b>	<b>1.22</b>	<b>0.85</b>	<b>0.57</b>	<b>0.44</b>				
3.80	R		18.15	5.89	2.49	1.04	0.40	0.22				
	V		<b>2.91</b>	<b>1.83</b>	<b>1.28</b>	<b>0.89</b>	<b>0.60</b>	<b>0.46</b>				
4.00	R		19.94	6.46	2.73	1.14	0.43	0.24				
	V		<b>3.06</b>	<b>1.93</b>	<b>1.35</b>	<b>0.94</b>	<b>0.63</b>	<b>0.49</b>				
4.50	R		24.77	8.00	3.37	1.41	0.53	0.29	0.09			
	V		<b>3.44</b>	<b>2.17</b>	<b>1.52</b>	<b>1.06</b>	<b>0.71</b>	<b>0.55</b>	<b>0.33</b>			
5.00	R		30.08	9.70	4.08	1.70	0.64	0.35	0.11			
	V		<b>3.82</b>	<b>2.41</b>	<b>1.69</b>	<b>1.18</b>	<b>0.79</b>	<b>0.61</b>	<b>0.37</b>			
5.50	R		11.55	4.85	2.02	0.76	0.41	0.13				
	V		<b>2.65</b>	<b>1.86</b>	<b>1.29</b>	<b>0.86</b>	<b>0.67</b>	<b>0.41</b>				
6.00	R		13.54	5.69	2.36	0.89	0.48	0.15				
	V		<b>2.89</b>	<b>2.03</b>	<b>1.41</b>	<b>0.94</b>	<b>0.73</b>	<b>0.45</b>				
6.50	R		15.69	6.58	2.73	1.03	0.56	0.17				
	V		<b>3.13</b>	<b>2.20</b>	<b>1.53</b>	<b>1.02</b>	<b>0.79</b>	<b>0.48</b>				
7.00	R		17.99	7.53	3.12	1.18	0.64	0.20	0.07			
	V		<b>3.37</b>	<b>2.36</b>	<b>1.65</b>	<b>1.10</b>	<b>0.85</b>	<b>0.52</b>	<b>0.33</b>			
7.50	R		20.43	8.55	3.53	1.33	0.72	0.22	0.08			
	V		<b>3.61</b>	<b>2.53</b>	<b>1.76</b>	<b>1.18</b>	<b>0.91</b>	<b>0.56</b>	<b>0.36</b>			
8.00	R		9.62	3.97	1.50	0.81	0.25	0.08				
	V		<b>2.70</b>	<b>1.88</b>	<b>1.26</b>	<b>0.98</b>	<b>0.60</b>	<b>0.38</b>				
8.50	R		10.75	4.44	1.67	0.90	0.28	0.09				
	V		<b>2.87</b>	<b>2.00</b>	<b>1.34</b>	<b>1.04</b>	<b>0.63</b>	<b>0.40</b>				
9.00	R		11.95	4.93	1.85	1.00	0.31	0.10				
	V		<b>3.04</b>	<b>2.12</b>	<b>1.41</b>	<b>1.10</b>	<b>0.67</b>	<b>0.43</b>				
9.50	R		13.20	5.44	2.04	1.10	0.34	0.11				
	V		<b>3.21</b>	<b>2.23</b>	<b>1.49</b>	<b>1.16</b>	<b>0.71</b>	<b>0.45</b>				
10.00	R		14.51	5.97	2.24	1.21	0.37	0.13				
	V		<b>3.38</b>	<b>2.35</b>	<b>1.57</b>	<b>1.22</b>	<b>0.74</b>	<b>0.48</b>				
10.50	R		15.88	6.53	2.45	1.32	0.40	0.14	0.05			
	V		<b>3.55</b>	<b>2.47</b>	<b>1.65</b>	<b>1.28</b>	<b>0.78</b>	<b>0.50</b>	<b>0.32</b>			
11.00	R		7.11	2.67	1.44	0.44	0.15	0.05				
	V		<b>2.59</b>	<b>1.73</b>	<b>1.34</b>	<b>0.82</b>	<b>0.52</b>	<b>0.33</b>				
11.50	R		7.72	2.89	1.56	0.47	0.16	0.06				
	V		<b>2.70</b>	<b>1.81</b>	<b>1.40</b>	<b>0.86</b>	<b>0.55</b>	<b>0.35</b>				
12.00	R		8.35	3.13	1.69	0.51	0.17	0.06				
	V		<b>2.82</b>	<b>1.89</b>	<b>1.46</b>	<b>0.89</b>	<b>0.57</b>	<b>0.36</b>				
12.50	R		9.00	3.37	1.82	0.55	0.19	0.06				
	V		<b>2.94</b>	<b>1.96</b>	<b>1.52</b>	<b>0.93</b>	<b>0.59</b>	<b>0.38</b>				
13.00	R		9.68	3.62	1.95	0.59	0.20	0.07				
	V		<b>3.06</b>	<b>2.04</b>	<b>1.58</b>	<b>0.97</b>	<b>0.62</b>	<b>0.40</b>				
13.50	R		10.37	3.88	2.09	0.63	0.22	0.07				
	V		<b>3.17</b>	<b>2.12</b>	<b>1.65</b>	<b>1.00</b>	<b>0.64</b>	<b>0.41</b>				
14.00	R		11.10	4.14	2.23	0.67	0.23	0.08				
	V		<b>3.29</b>	<b>2.20</b>	<b>1.71</b>	<b>1.04</b>	<b>0.67</b>	<b>0.43</b>				

Table 4.13

## MecFlow Fusion – pressure loss

FLOW l/s	EXTERNAL DIAMETER mm	40	50	63	75	90	110	125	160	200	250	315
	THICKNESS mm	3.7	4.6	5.8	6.8	8.2	10	11.4	14.6	18.2	22.7	28.6
	INTERNAL DIAMETER mm	32.6	40.8	51.4	61.4	73.6	90.0	102.2	130.8	163.6	204.6	257.8
	'R'– PRESSURE LOSS (mbar/m)	'V'– VELOCITY (m/s)										
14.50	R					11.84	4.42	2.38	0.72	0.24	0.08	
	V					<b>3.41</b>	<b>2.28</b>	<b>1.77</b>	<b>1.08</b>	<b>0.69</b>	<b>0.44</b>	
15.00	R					12.61	4.70	2.53	0.76	0.26	0.09	
	V					<b>3.53</b>	<b>2.36</b>	<b>1.83</b>	<b>1.12</b>	<b>0.71</b>	<b>0.46</b>	
15.50	R					4.99	2.69	0.81	0.28	0.09	0.03	
	V					<b>2.44</b>	<b>1.89</b>	<b>1.15</b>	<b>0.74</b>	<b>0.47</b>	<b>0.30</b>	
16.00	R					5.29	2.85	0.86	0.29	0.10	0.03	
	V					<b>2.52</b>	<b>1.95</b>	<b>1.19</b>	<b>0.76</b>	<b>0.49</b>	<b>0.31</b>	
16.50	R					5.60	3.01	0.91	0.31	0.11	0.03	
	V					<b>2.59</b>	<b>2.01</b>	<b>1.23</b>	<b>0.78</b>	<b>0.50</b>	<b>0.32</b>	
17.00	R					5.92	3.18	0.96	0.33	0.11	0.04	
	V					<b>2.67</b>	<b>2.07</b>	<b>1.27</b>	<b>0.81</b>	<b>0.52</b>	<b>0.33</b>	
17.50	R					6.24	3.35	1.01	0.34	0.12	0.04	
	V					<b>2.75</b>	<b>2.13</b>	<b>1.30</b>	<b>0.83</b>	<b>0.53</b>	<b>0.34</b>	
18.00	R					6.58	3.53	1.06	0.36	0.12	0.04	
	V					<b>2.83</b>	<b>2.19</b>	<b>1.34</b>	<b>0.86</b>	<b>0.55</b>	<b>0.34</b>	
18.50	R					6.92	3.71	1.12	0.38	0.13	0.04	
	V					<b>2.91</b>	<b>2.26</b>	<b>1.38</b>	<b>0.88</b>	<b>0.56</b>	<b>0.35</b>	
19.00	R					7.27	3.90	1.17	0.40	0.14	0.04	
	V					<b>2.99</b>	<b>2.32</b>	<b>1.41</b>	<b>0.90</b>	<b>0.58</b>	<b>0.36</b>	
19.50	R					7.63	4.09	1.23	0.42	0.14	0.05	
	V					<b>3.07</b>	<b>2.38</b>	<b>1.45</b>	<b>0.93</b>	<b>0.59</b>	<b>0.37</b>	
20.00	R					7.99	4.29	1.29	0.44	0.15	0.05	
	V					<b>3.14</b>	<b>2.44</b>	<b>1.49</b>	<b>0.95</b>	<b>0.61</b>	<b>0.38</b>	
20.50	R					8.37	4.49	1.35	0.46	0.16	0.05	
	V					<b>3.22</b>	<b>2.50</b>	<b>1.53</b>	<b>0.98</b>	<b>0.62</b>	<b>0.39</b>	
21.00	R					8.75	4.69	1.41	0.48	0.16	0.05	
	V					<b>3.30</b>	<b>2.56</b>	<b>1.56</b>	<b>1.00</b>	<b>0.64</b>	<b>0.40</b>	
21.50	R					9.14	4.90	1.47	0.50	0.17	0.06	
	V					<b>3.38</b>	<b>2.62</b>	<b>1.60</b>	<b>1.02</b>	<b>0.65</b>	<b>0.41</b>	
22.00	R					9.54	5.11	1.53	0.52	0.18	0.06	
	V					<b>3.46</b>	<b>2.68</b>	<b>1.64</b>	<b>1.05</b>	<b>0.67</b>	<b>0.42</b>	
22.50	R					9.94	5.33	1.60	0.54	0.18	0.06	
	V					<b>3.54</b>	<b>2.74</b>	<b>1.67</b>	<b>1.07</b>	<b>0.68</b>	<b>0.43</b>	
23.00	R					5.55	1.66	0.56	0.19	0.06		
	V					<b>2.80</b>	<b>1.71</b>	<b>1.09</b>	<b>0.70</b>	<b>0.44</b>		
23.50	R					5.77	1.73	0.58	0.20	0.07		
	V					<b>2.86</b>	<b>1.75</b>	<b>1.12</b>	<b>0.71</b>	<b>0.45</b>		
24.00	R					6.00	1.80	0.61	0.21	0.07		
	V					<b>2.93</b>	<b>1.79</b>	<b>1.14</b>	<b>0.73</b>	<b>0.46</b>		
24.50	R					6.23	1.87	0.63	0.21	0.07		
	V					<b>2.99</b>	<b>1.82</b>	<b>1.17</b>	<b>0.75</b>	<b>0.47</b>		
25.00	R					6.47	1.94	0.65	0.22	0.07		
	V					<b>3.05</b>	<b>1.86</b>	<b>1.19</b>	<b>0.76</b>	<b>0.48</b>		

## MecFlow Fusion – pressure loss

FLOW l/s	EXTERNAL DIAMETER mm	40	50	63	75	90	110	125	160	200	250	315		
	THICKNESS mm	3.7	4.6	5.8	6.8	8.2	10	11.4	14.6	18.2	22.7	28.6		
	INTERNAL DIAMETER mm	32.6	40.8	51.4	61.4	73.6	90.0	102.2	130.8	163.6	204.6	257.8		
	'R'– PRESSURE LOSS (mbar/m)	'V'– VELOCITY (m/s)												
27.00	R									7.46	2.23	0.75	0.25	0.08
	V									<b>3.29</b>	<b>2.01</b>	<b>1.28</b>	<b>0.87</b>	<b>0.52</b>
27.50	R									7.72	2.31	0.78	0.26	0.09
	V									<b>3.35</b>	<b>2.05</b>	<b>1.31</b>	<b>0.84</b>	<b>0.53</b>
28.00	R									7.98	2.38	0.80	0.27	0.09
	V									<b>3.41</b>	<b>2.08</b>	<b>1.33</b>	<b>0.85</b>	<b>0.54</b>
28.50	R									8.25	2.46	0.83	0.28	0.09
	V									<b>3.47</b>	<b>2.12</b>	<b>1.36</b>	<b>0.87</b>	<b>0.55</b>
29.00	R									8.52	2.54	0.86	0.29	0.10
	V									<b>3.54</b>	<b>2.16</b>	<b>1.38</b>	<b>0.88</b>	<b>0.56</b>
29.50	R									2.62	0.88	0.30	0.10	
	V									<b>2.20</b>	<b>1.40</b>	<b>0.90</b>	<b>0.57</b>	
30.00	R									2.71	0.91	0.31	0.10	
	V									<b>2.23</b>	<b>1.43</b>	<b>0.91</b>	<b>0.57</b>	
30.50	R									2.79	0.94	0.32	0.10	
	V									<b>2.27</b>	<b>1.45</b>	<b>0.93</b>	<b>0.58</b>	
31.00	R									2.87	0.97	0.33	0.11	
	V									<b>2.31</b>	<b>1.47</b>	<b>0.94</b>	<b>0.59</b>	
31.50	R									2.96	0.99	0.34	0.11	
	V									<b>2.34</b>	<b>1.50</b>	<b>0.96</b>	<b>0.60</b>	
32.00	R									3.05	1.02	0.35	0.11	
	V									<b>2.38</b>	<b>1.52</b>	<b>0.97</b>	<b>0.61</b>	
32.50	R									3.13	1.05	0.36	0.12	
	V									<b>2.42</b>	<b>1.55</b>	<b>0.99</b>	<b>0.62</b>	
33.00	R									3.22	1.08	0.37	0.12	
	V									<b>2.46</b>	<b>1.57</b>	<b>1.00</b>	<b>0.63</b>	
33.50	R									3.31	1.11	0.38	0.12	
	V									<b>2.49</b>	<b>1.59</b>	<b>1.02</b>	<b>0.64</b>	
34.00	R									3.41	1.14	0.39	0.13	
	V									<b>2.53</b>	<b>1.62</b>	<b>1.03</b>	<b>0.65</b>	
34.50	R									3.50	1.17	0.40	0.13	
	V									<b>2.57</b>	<b>1.64</b>	<b>1.05</b>	<b>0.66</b>	
35.00	R									3.59	1.21	0.41	0.13	
	V									<b>2.60</b>	<b>1.66</b>	<b>1.06</b>	<b>0.67</b>	
35.50	R									3.69	1.24	0.42	0.14	
	V									<b>2.64</b>	<b>1.69</b>	<b>1.08</b>	<b>0.68</b>	
36.00	R									3.79	1.27	0.43	0.14	
	V									<b>2.68</b>	<b>1.71</b>	<b>1.09</b>	<b>0.69</b>	
36.50	R									3.88	1.30	0.44	0.14	
	V									<b>2.72</b>	<b>1.74</b>	<b>1.11</b>	<b>0.70</b>	
37.00	R									3.98	1.33	0.45	0.15	
	V									<b>2.75</b>	<b>1.76</b>	<b>1.13</b>	<b>0.71</b>	
37.50	R									4.08	1.37	0.46	0.15	
	V									<b>2.79</b>	<b>1.78</b>	<b>1.14</b>	<b>0.72</b>	
38.00	R									4.18	1.40	0.47	0.15	
	V									<b>2.83</b>	<b>1.81</b>	<b>1.16</b>	<b>0.73</b>	
38.50	R									4.29	1.44	0.48	0.16	
	V									<b>2.87</b>	<b>1.83</b>	<b>1.17</b>	<b>0.74</b>	
39.00	R									4.39	1.47	0.50	0.16	
	V									<b>2.90</b>	<b>1.86</b>	<b>1.19</b>	<b>0.75</b>	

Table 4.15

## MecFlow Fusion – pressure loss

FLOW l/s	EXTERNAL DIAMETER mm	40	50	63	75	90	110	125	160	200	250	315				
	THICKNESS mm	3.7	4.6	5.8	6.8	8.2	10	11.4	14.6	18.2	22.7	28.6				
	INTERNAL DIAMETER mm	32.6	40.8	51.4	61.4	73.6	90.0	102.2	130.8	163.6	204.6	257.8				
	'R'– PRESSURE LOSS (mbar/m)	'V'– VELOCITY (m/s)														
39.50	R												4.50	1.50	0.51	0.17
	V												<b>2.94</b>	<b>1.88</b>	<b>1.20</b>	<b>0.76</b>
40.00	R												4.60	1.54	0.52	0.17
	V												<b>2.98</b>	<b>1.90</b>	<b>1.22</b>	<b>0.77</b>
40.50	R												4.71	1.58	0.53	0.17
	V												<b>3.01</b>	<b>1.93</b>	<b>1.23</b>	<b>0.78</b>
41.00	R												4.82	1.61	0.54	0.18
	V												<b>3.05</b>	<b>1.95</b>	<b>1.25</b>	<b>0.79</b>
41.50	R												4.93	1.65	0.56	0.18
	V												<b>3.09</b>	<b>1.97</b>	<b>1.26</b>	<b>0.80</b>
42.00	R												5.04	1.68	0.57	0.19
	V												<b>3.13</b>	<b>2.00</b>	<b>1.28</b>	<b>0.80</b>
42.50	R												5.15	1.72	0.58	0.19
	V												<b>3.16</b>	<b>2.02</b>	<b>1.29</b>	<b>0.81</b>
43.00	R												5.26	1.76	0.59	0.19
	V												<b>3.20</b>	<b>2.05</b>	<b>1.31</b>	<b>0.82</b>
43.50	R												5.38	1.80	0.60	0.20
	V												<b>3.24</b>	<b>2.07</b>	<b>1.32</b>	<b>0.83</b>
44.00	R												5.49	1.83	0.62	0.20
	V												<b>3.27</b>	<b>2.09</b>	<b>1.34</b>	<b>0.84</b>
44.50	R												5.61	1.87	0.63	0.21
	V												<b>3.31</b>	<b>2.12</b>	<b>1.35</b>	<b>0.85</b>
45.00	R												5.73	1.91	0.64	0.21
	V												<b>3.35</b>	<b>2.14</b>	<b>1.37</b>	<b>0.86</b>
45.50	R												5.85	1.95	0.66	0.21
	V												<b>3.39</b>	<b>2.16</b>	<b>1.38</b>	<b>0.87</b>
46.00	R												5.97	1.99	0.67	0.22
	V												<b>3.42</b>	<b>2.19</b>	<b>1.40</b>	<b>0.88</b>
46.50	R												6.09	2.03	0.68	0.22
	V												<b>3.46</b>	<b>2.21</b>	<b>1.41</b>	<b>0.89</b>
47.00	R												6.21	2.07	0.70	0.23
	V												<b>3.50</b>	<b>2.24</b>	<b>1.43</b>	<b>0.90</b>
47.50	R													2.11	0.71	0.23
	V												<b>2.26</b>	<b>1.44</b>	<b>0.91</b>	
48.00	R													2.15	0.72	0.24
	V												<b>2.28</b>	<b>1.46</b>	<b>0.92</b>	
48.50	R													2.19	0.74	0.24
	V												<b>2.31</b>	<b>1.48</b>	<b>0.93</b>	
49.00	R													2.24	0.75	0.25
	V												<b>2.33</b>	<b>1.49</b>	<b>0.94</b>	
49.50	R													2.28	0.77	0.25
	V												<b>2.35</b>	<b>1.51</b>	<b>0.95</b>	
50.00	R													2.32	0.78	0.25
	V												<b>2.38</b>	<b>1.52</b>	<b>0.96</b>	
50.50	R													2.36	0.79	0.26
	V												<b>2.40</b>	<b>1.54</b>	<b>0.97</b>	
51.00	R													2.41	0.81	0.26
	V												<b>2.43</b>	<b>1.55</b>	<b>0.98</b>	
51.50	R													2.45	0.82	0.27
	V												<b>2.45</b>	<b>1.57</b>	<b>0.99</b>	

Table 4.16

## MecFlow Fusion – pressure loss

FLOW l/s	EXTERNAL DIAMETER mm	40	50	63	75	90	110	125	160	200	250	315	
	THICKNESS mm	3.7	4.6	5.8	6.8	8.2	10	11.4	14.6	18.2	22.7	28.6	
	INTERNAL DIAMETER mm	32.6	40.8	51.4	61.4	73.6	90.0	102.2	130.8	163.6	204.6	257.8	
'R'– PRESSURE LOSS (mbar/m)		'V'– VELOCITY (m/s)											
52.00	R										2.50	0.84	0.27
	V										2.47	1.58	1.00
52.50	R										2.54	0.85	0.28
	V										2.50	1.60	1.01
53.00	R										2.59	0.87	0.28
	V										2.52	1.61	1.02
53.50	R										2.63	0.88	0.29
	V										2.55	1.63	1.02
54.00	R										2.68	0.90	0.29
	V										2.57	1.64	1.03
54.50	R										2.72	0.91	0.30
	V										2.59	1.66	1.04
55.00	R										2.77	0.93	0.30
	V										2.62	1.67	1.05
55.50	R										2.82	0.94	0.31
	V										2.64	1.69	1.06
56.00	R										2.86	0.96	0.31
	V										2.66	1.70	1.07
56.50	R										2.91	0.98	0.32
	V										2.69	1.72	1.08
57.00	R										2.96	0.99	0.32
	V										2.71	1.73	1.09
57.50	R										3.01	1.01	0.33
	V										2.74	1.75	1.10
58.00	R										3.06	1.02	0.33
	V										2.76	1.76	1.11
58.50	R										3.10	1.04	0.34
	V										2.78	1.78	1.12
59.00	R										3.15	1.06	0.34
	V										2.81	1.79	1.13
59.50	R										3.20	1.07	0.35
	V										2.83	1.81	1.14
60.00	R										3.25	1.09	0.35
	V										2.85	1.82	1.15
60.50	R										3.30	1.11	0.36
	V										2.88	1.84	1.16
61.00	R										3.35	1.12	0.37
	V										2.90	1.86	1.17
61.50	R										3.41	1.14	0.37
	V										2.93	1.87	1.18
62.00	R										3.46	1.16	0.38
	V										2.95	1.89	1.19
62.50	R										3.51	1.17	0.38
	V										2.97	1.90	1.20
63.00	R										3.56	1.19	0.39
	V										3.00	1.92	1.21
63.50	R										3.61	1.21	0.39
	V										3.02	1.93	1.22
64.00	R										3.67	1.23	0.40
	V										3.04	1.95	1.23

Table 4.17

## MecFlow Fusion – pressure loss

FLOW l/s	EXTERNAL DIAMETER mm	40	50	63	75	90	110	125	160	200	250	315		
	THICKNESS mm	3.7	4.6	5.8	6.8	8.2	10	11.4	14.6	18.2	22.7	28.6		
	INTERNAL DIAMETER mm	32.6	40.8	51.4	61.4	73.6	90.0	102.2	130.8	163.6	204.6	257.8		
'R'– PRESSURE LOSS (mbar/m)		'V'– VELOCITY (m/s)												
64.50	R											3.72	1.24	0.40
	V											3.07	1.96	1.24
65.00	R											3.77	1.26	0.41
	V											3.09	1.98	1.25
65.50	R											3.83	1.28	0.42
	V											3.12	1.99	1.25
66.00	R											3.88	1.30	0.42
	V											3.14	2.01	1.26
66.50	R											3.94	1.32	0.43
	V											3.16	2.02	1.27
67.00	R											3.99	1.33	0.43
	V											3.19	2.04	1.28
67.50	R											4.05	1.35	0.44
	V											3.21	2.05	1.29
68.00	R											4.11	1.37	0.45
	V											3.23	2.07	1.30
68.50	R											4.16	1.39	0.45
	V											3.26	2.08	1.31
69.00	R											4.22	1.41	0.46
	V											3.28	2.10	1.32
69.50	R											4.28	1.43	0.46
	V											3.31	2.11	1.33
70.00	R											4.33	1.45	0.47
	V											3.33	2.13	1.34
70.50	R											4.39	1.47	0.48
	V											3.35	2.14	1.35
71.00	R											4.45	1.49	0.48
	V											3.38	2.16	1.36
71.50	R											4.51	1.50	0.49
	V											3.40	2.17	1.37
72.00	R											4.57	1.52	0.49
	V											3.43	2.19	1.38
72.50	R											4.63	1.54	0.50
	V											3.45	2.21	1.39
73.00	R											4.69	1.56	0.51
	V											3.47	2.22	1.40
73.50	R											4.75	1.58	0.51
	V											3.50	2.24	1.41
74.00	R												1.60	0.52
	V												2.25	1.42
74.50	R												1.62	0.53
	V												2.27	1.43
75.00	R												1.64	0.53
	V												2.28	1.44
75.50	R												1.66	0.54
	V												2.30	1.45
76.00	R												1.68	0.55
	V												2.31	1.46
76.50	R												1.70	0.55
	V												2.33	1.47

Table 4.18

## MecFlow Fusion – pressure loss

FLOW l/s	EXTERNAL DIAMETER mm	40	50	63	75	90	110	125	160	200	250	315
	THICKNESS mm	3.7	4.6	5.8	6.8	8.2	10	11.4	14.6	18.2	22.7	28.6
	INTERNAL DIAMETER mm	32.6	40.8	51.4	61.4	73.6	90.0	102.2	130.8	163.6	204.6	257.8
	'R'– PRESSURE LOSS (mbar/m)	'V'– VELOCITY (m/s)										
77.00	R										1.73	0.56
	V										2.34	1.48
77.50	R										1.75	0.57
	V										2.36	1.48
78.00	R										1.77	0.57
	V										2.37	1.49
78.50	R										1.79	0.58
	V										2.39	1.50
79.00	R										1.81	0.59
	V										2.40	1.51
79.50	R										1.83	0.59
	V										2.42	1.52
80.00	R										1.85	0.60
	V										2.43	1.53
80.50	R										1.87	0.61
	V										2.45	1.54
81.00	R										1.89	0.61
	V										2.46	1.55
81.50	R										1.92	0.62
	V										2.48	1.56
82.00	R										1.94	0.63
	V										2.49	1.57
82.50	R										1.96	0.63
	V										2.51	1.58
83.00	R										1.98	0.64
	V										2.52	1.59
83.50	R										2.03	0.65
	V										2.55	1.60
84.00	R										2.05	0.66
	V										2.57	1.61
84.50	R										2.07	0.66
	V										2.59	1.62
85.00	R										2.30	0.67
	V										2.74	1.63
90.00	R										2.55	0.74
	V										2.89	1.72
95.00	R										2.80	0.82
	V										3.04	1.82
100.00	R										3.35	0.90
	V										3.35	1.97
110.00	R										3.94	1.08
	V										3.65	2.11
120.00	R											1.26
	V											2.30
130.00	R											1.47
	V											2.49
140.00	R											1.68
	V											2.68
150.00	R											1.91
	V											2.87

Table 4.19

## MecFlow Fusion – pressure loss

FLOW l/s	EXTERNAL DIAMETER mm	40	50	63	75	90	110	125	160	200	250	315
	THICKNESS mm	3.7	4.6	5.8	6.8	8.2	10	11.4	14.6	18.2	22.7	28.6
	INTERNAL DIAMETER mm	32.6	40.8	51.4	61.4	73.6	90.0	102.2	130.8	163.6	204.6	257.8
	'R'– PRESSURE LOSS (mbar/m)	'V'– VELOCITY (m/s)										
160.00	R											2.16
	V											3.07
170.00	R											2.42
	V											3.26
180.00	R											2.69
	V											3.45
190.00	R											2.98
	V											3.64
200.00	R											
	V											
220.00	R											
	V											
220.00	R											
	V											
230.00	R											
	V											
240.00	R											
	V											
250.00	R											
	V											
260.00	R											
	V											
270.00	R											
	V											
280.00	R											
	V											
290.00	R											
	V											
300.00	R											
	V											

Table 4.20

# 5. Technical specification

## System description

The MecFlow Fusion system shall be as indicated on the drawings, manufactured in accordance with ISO 9001 and delivered within the agreed programme of works.

The product shall be designed and delivered as a fabricated solution in accordance with site specific design criteria with welds pre-tested during the manufacturing process.

The system shall be manufactured using multi-layer pipe technology made from reinforced Polypropylene, suitable for use in the following applications:

1. Boosted Cold Water
2. LPHW / LTHW
3. Chilled Water
4. Heating

The MecFlow Fusion product shall be suitable for water temperatures up to 95°C. Operating pressures vary dependant on fluid temperatures, as displayed in the Working Pressures table within the MecFlow Technical Manual.

Pipework joints and connections are to be made utilising patented CLICKWELD™ electrofusion jointing methods, providing a homogenous weld. Where CLICKWELD™ fittings are not provided, joints shall be made utilising MecFlow electrofusion couplings.

The CLICKWELD™ jointing method shall permit the installation to be carried out, without the requirement to clamp pipework in place prior to the jointing procedures being carried out.

The CLICKWELD™ and electrofusion-coupling jointing procedure shall be able to be carried out utilising one electrofusion coupling machine.

TEMPERATURE	YEARS OF SERVICE	MECFLOW DIAMETERS 20 - 32mm		MECFLOW DIAMETERS 40 - 400mm WALL THICKNESS 10mm	
		BAR	PSI	BAR	PSI
10°C	1	39.20	568.52	25.08	363.75
	5	38.20	554.04	24.40	353.89
	10	37.57	544.90	24.04	348.67
	25	36.75	533.01	23.52	341.12
	50	36.50	529.38	23.36	338.80
20°C	100	35.95	521.41	23.00	333.58
	1	34.15	495.30	21.85	316.90
	5	33.05	479.34	21.15	306.75
	10	32.77	474.70	20.97	304.14
	25	32.00	464.12	20.48	297.03
30°C	50	31.70	459.76	20.30	294.42
	100	31.10	451.79	19.93	289.06
	1	29.80	432.21	19.08	276.73
	5	29.00	420.60	18.56	269.19
	10	28.45	412.63	18.20	263.96
40°C	25	27.90	404.65	17.85	258.89
	50	27.62	400.59	17.68	256.42
	100	27.05	392.32	17.31	251.06
	1	26.05	377.82	16.67	241.77
	5	25.20	365.49	16.12	233.80
50°C	10	24.65	357.51	15.77	228.72
	25	24.37	353.45	15.60	226.25
	50	23.82	345.47	15.24	221.03
	100	23.52	341.12	15.05	218.28
	1	23.05	334.31	14.75	213.93
60°C	5	22.17	321.54	14.19	205.80
	10	21.60	313.28	13.82	200.44
	25	21.30	308.93	13.63	197.78
	50	20.75	300.95	13.20	191.44
	100	20.45	296.60	13.00	188.54
70°C	1	19.37	280.93	12.40	179.84
	5	18.80	272.67	12.03	174.48
	10	18.50	268.31	11.84	171.72
	25	17.92	259.90	11.47	166.35
	50	17.70	256.71	11.30	163.89
80°C	1	16.55	240.03	10.59	153.59
	5	15.67	227.27	10.00	145.03
	10	15.40	223.35	9.85	142.86
	25	15.10	219.00	9.66	140.10
	50	14.90	216.10	9.50	137.78
95°C	1	13.82	200.44	8.84	128.21
	5	13.22	191.73	8.46	122.70
	10	12.92	187.38	8.27	119.94
	25	12.70	184.19	8.10	117.48
	1	10.75	155.91	6.88	99.78
	5	10.15	147.21	6.49	94.12

Table 5.01

$$P = \frac{\sigma}{S \times SF}$$

p = Admissible work pressure  
 σ = Hydrostatic effort at MPa  
 S = Pipes series  
 SF = Security factor

### Working pressure supported by the pipes for pressurised water.

The maximum work pressures according to the resistance equation to the internal pressure in accordance with DIN 8078, bearing in mind a security factor SF.

## System description

TECHNICAL CHARACTERISTICS			
PROPERTIES	VALUES	UNITS	STANDARDS
Material	PPR CT RP + FV	-	-
Density	>0.93	g/cm3	ISO 1183
Melt mass flow rate (230°C/2,16kg)	0.25	g/10'	ISO 1133
Hydrostatic (hoop) stress (20°C-1h) a 15 Mpa	No fault	-	ISO 1167
Hydrostatic (hoop) stress (95°-22h) a 4.2 Mpa	No fault	-	ISO 1167
Hydrostatic (hoop) stress (95°C-165h) a 4.0 Mpa	No fault	-	ISO 1167
Hydrostatic (hoop) stress (95°C-1000h) a 3.8 Mpa	No fault	-	ISO 1167
Thermal stability (110°C-8760 h) a 2.6 Mpa	No fault	-	ISO 1167
Longitudinal retraction (135°C)	<2	%	ISO 2505
Tensile Modulus	>950	Mpa	ISO 527
Tensile strain at yield	>12	%	ISO 527
Esfuerzo de tracción en el punto de fluencia	>30	Mpa	ISO 527
Lineal thermal expansion	<0.04	mm/m°C	-
Thermal conductivity coefficient	0.24	W/m °C	DIN 52612
Opacity	SI	-	ISO 7686
Impact resistance determination (ball drop method)	H50≥1m (s3,2) H50≥0.7m (s4 - s5 - s6,3- s8)	m	EN 1411
Roughness k	0.003	mm	-

Table 5.02

The MecFlow Fusion product shall be offered to meet fire classification level B-s1,d0 in accordance with EN13501.

The MecFlow Fusion product is a low smoke, zero halogen product with anti-microbial and anti-fouling properties built into the product. The product is disinfection resistant with no degradation of the pipe during the disinfection process.

The MecFlow Fusion product is UV stabilised and has a high abrasion resistance ensuring a durable, reliable product during installation.

The MecFlow Fusion product range offers comprehensive solutions inclusive of riser pipework, run-out to manifolds, run-out to corridor (with tee connections into separate supply areas), as well as a range of two to twelve-port manifolds (other combinations to be made available upon request).

MecFlow Fusion products shall be supplied with minimal packaging. Where items are to be supplied loose (in the case of electrofusion couplings), they are to be supplied in returnable totes, to minimise the quantity of waste on-site. Where possible, pipework systems shall be delivered on returnable stillages.

## STORAGE & HANDLING

### Handling

- Take all care when handling PPR-CT particularly in very cold conditions when the impact strength of the material is reduced.
- Do not throw or drop pipes, or drag them along hard surfaces.
- In case of mechanical handling, use protective slings and padded supports. Metal chains and hooks should not make contact with the pipe.

### On-site storage

- Stack pipe lengths either:
  - on a flat base
  - on level ground
  - on 75mm x 75mm timber at 1m centres.
- Provide side support with 75mm wide battens at 1m centres.
- Maximum stack (normal conditions): three layers high.
- Ideally, stacks should contain one diameter pipe size only. Where this is not possible, stack largest diameter pipes at the base of stack. Smaller diameter pipes may be nested inside larger diameter pipes.
- Pipes and fittings must not be stored externally and must be protected from dirt ingress and sunlight.
- Do not remove fittings from cartons or packaging until required.

### Site safety

The relevant regulations detailed in the Health and Safety at Work Act 1974, and Construction (Design & Management) regulations 2015, must be adhered to on site.

## INSTALLATION

The pipework should be insulated (by others) in accordance with the application of use and specification requirements.

The Installation Engineer shall take care to ensure adequate bracketry and fire sleeves are used as per the specification requirements.

## TESTING

The MecFlow Fusion product will be supplied with pre-tested welds for fabricated sections of pipework. Post-installation testing shall be carried out in-line with the specification requirements to ensure all electrofusion couplings have been fired correctly as per manufacturer guidelines.

## FLUSHING

The MecFlow Fusion product shall be flushed in accordance with the specification requirements.

# 6. Jointing methods

## Thermo welding

One advantage of MecFlow Fusion over traditional water supply systems is its ability to offer thermo welded joints, creating a consistent, robust joint for the lifecycle of the installation.

Effectively eliminating the boundary between the pipe and the fitting, thermo welding provides a homogenous joint, bonded at a molecular level, effectively making the join as strong as the pipe itself. The MecFlow Fusion system has three methods of thermo welding: butt fusion, socket fusion, and electrofusion, all of which use a heat source to facilitate an effective weld process. Using electrofusion, the patented CLICKWELD™ technology provides a unique, robust and simple jointing method.

Table 6.01 shows the diameters which can be welded via each process.

### MECHANICAL JOINTING

In addition to thermo welding, a large range of threaded and flanged jointing methods are available, allowing the MecFlow Fusion system to be jointed to other materials, and to connect valves and other system components.

PIPE Ø	WELDING OPTIONS													
	20	25	32	40	50	63	75	90	110	125	160	200	250	315
<b>Pipe to Pipe</b>														
Socket*	✓	✓	✓	✓	✓	✓	✓	✓	✓	✓				
Butt				✓	✓	✓	✓	✓	✓	✓	✓	✓	✓	✓
Electrofusion**	✓	✓	✓	✓	✓	✓	✓	✓	✓	✓	✓	✓	✓	✓
CLICKWELD™					✓	✓	✓	✓	✓	✓				
<b>Pipe to Fitting</b>														
Socket***	✓	✓	✓	✓	✓	✓	✓	✓	✓	✓				
Butt											✓	✓	✓	✓
Electrofusion**											✓	✓	✓	✓
CLICKWELD™					✓	✓	✓	✓	✓	✓				

Table 6.01  
 \*Using double socket.  
 \*\*Using electrofusion coupling.  
 \*\*\*Primary connection on reducer can be butt welded to pipe (>40mm), socket welded to pipe using double socket coupling or socket welded within fitting.

KEY  
 ✓ = Available

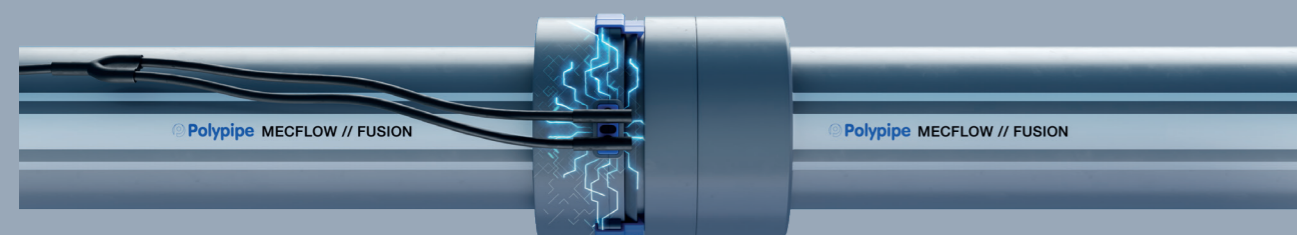

## Jointing preparation

### Pipe cutting

There are a number of methods of correctly cutting pipe prior to joining. In all cases, the cut pipe should be square and de-burred. Additional preparation steps are included in the specific welding instructions as and when required. The cutting method and post-cutting preparation are detailed below.

### Manual pipe cutting

While these are the recommended cutting methods, other methods can be used, provided the pipe isn't damaged as a result. All cuts should be square, and without any jagged edges.



Hand saws may be used, however it is crucial to ensure the cut is square, and the edges are as smooth as possible.



Support the pipe during cutting to prevent movement, allowing the end to be cut as square as possible.



Alternatively, pipe cutters can be used. Ensure the cutting wheel has a radius greater than the pipe wall.

### DO NOT ✗

Do not use pipe cutters with a dull or flat blade. Blunt blades can oval the pipe and can cause an inconsistent cut.



**Recommendation:** Mobile work benches can be used as a clamping device to achieve a 90 degree cut.

## Jointing preparation (continued)

### Cutting using power tools

When using powered saws, fine toothed blades offer the best results. Where possible, avoid angled or jagged cuts, as additional preparation will be required prior to welding.



For a cut that requires minimal finishing work, use a fine-toothed circular tungsten carbide blade suitable for cutting plastic.



Both band saws and reciprocating saws may also be used.

**Recommendation:** Ensure blade is sharp and between 10-14tpi.

#### DO NOT ❌

Do not cut the pipe using power tools where the temperature is below 4°C. Place the pipe in an environment with a higher ambient temperature before cutting.



Attention: A wide tooth blade will result in a rough jagged cut.

### Inspection and cleaning/de-burring

#### ATTENTION !

A blunt or incorrect cutting tool may cause stresses during the cutting process, first check the cutting tool to ensure it is suitable. Pipe should not be cut below a temperature of 4°C



Once a cut is made, check the ends of the pipe for damage, both internally and externally. If any damage is identified, mark and remove the damaged area, cutting a few millimetres beyond the damage.



Remove any debris left after cutting and de-burr using a de-burring tool or reaming tool.



Dirt and oil should be removed from the pipe's surface using an isopropyl alcohol-based cleaner (91% by volume or greater).



A successful cut should be square, smooth and de-burred.

## Socket fusion welding

### SOCKET FUSION WELDING

Socket fusion welding is carried out by heating the outer surface of the pipe and the socket of a corresponding fitting, before inserting the pipe into the fitting.

The pipe is then held in the socket and allowed to cool. This forms a homogenous bond, with the weld surface covering the entire area of the pipe spigot/fitting socket

insertion. For pipe diameters up to 63mm, this process can be carried out by hand, however for diameters of 75mm and above, a socket fusion welding machine must be used.

#### Pre-welding process

1. Before carrying out the first weld, using a temperature probe, check that the, Type A, male and female irons have reached a temperature of 260°C.
2. Cut the pipe to the required length. The cut must be square and de-burred.
3. Bevel the pipe according to table 6.02.
4. Mark the pipe insertion depth on the pipe, as shown in diagram 6.03 (Only required when hand-welding).
5. Mark the desired angular rotation of the fitting to the pipe. If the fitting is a coupling, or the first bend or branch, this step is not required.

BEVELING AND INSERTION OF THE PIPES (DVS 2207-11)		
Ø PIPE 'D' mm	BEVELING 'b' mm	WELDING DEPTH 'L' mm
20	-	14
25	2	16
32	2	18
40	2	20
50	2	23
63	2	27
75	3	31
90	3	35
110	3	41
125	3	46

Table 6.02

Diagram 6.03

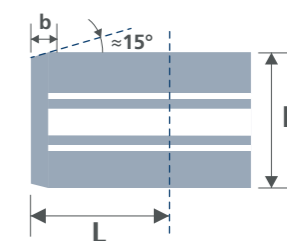

#### Welding process timing

There are a number of socket fusion machines available, each with different operation methods. The user should familiarise themselves with the correct method for their machine before welding.

TEMPERATURES & TIMES OF THERMO-FUSION (DVS 2207-11)				
PIPE OD mm	HEATING TIME (Seconds)	JOINT TIME (Seconds)	COOLING TIME	
			FIXED (Seconds)	TOTAL (Minutes)
20	6	4	6	2
25	7	4	10	2
32	8	6	10	4
40	12	6	20	4
50	18	6	20	4
63	24	8	30	6
75	30	8	30	6
90	40	8	40	6
110	50	10	50	8
125	60	10	60	8

Table 6.04

## Socket fusion welding (continued)

### HAND SOCKET FUSION WELDING – Ø20mm TO Ø63mm

#### Equipment and set-up

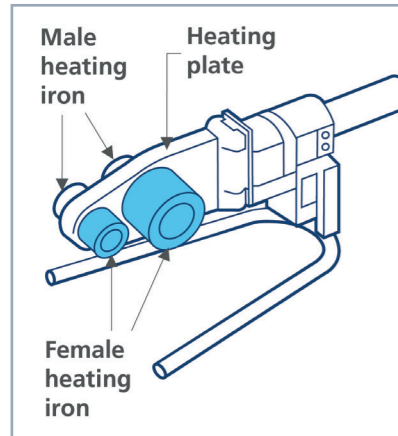

- The heating irons must be mounted into the correct hole on the hot plate, consult the tool's instruction manual if you are unsure which iron mounts to which hole.
- It is crucial that the base of the heating iron is in full contact with the hot plate, as shown diagram 6.05.

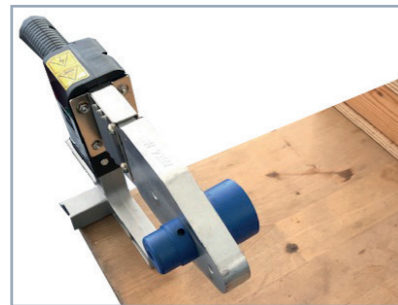

- Plug the hand welding device in and allow it to reach the correct welding temperature. Check temperature with a temperature probe prior to use to ensure it has reached 260°C.



Diagram 6.05



- Check the hand welding tool and relevant male/female irons for damage. If damaged, then replace before use.
- Before turning the hot plate on, the relevant Type A male and female heating irons must be mounted onto the base hand welding device. Make sure they are fitted square.

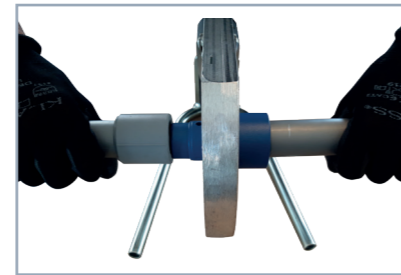

- Once all pre-welding steps are complete, push the pipe into the female iron and push the fitting on to the male iron. Insert to the mechanical stop. Do not twist the pipe or fitting.

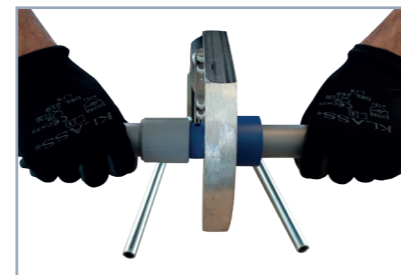

- Once the pipe and fitting both reach the mechanical stop, apply heat for the required time.

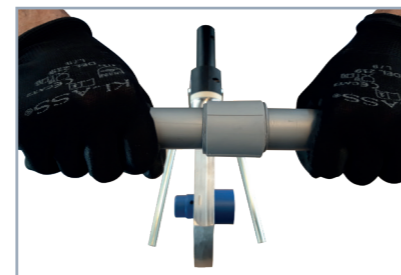

- Once the heating time is reached, remove the pipe and fitting from the hot plate, and immediately push them together, without twisting, to the insertion depth marked on the pipe. This must be completed within the joint time listed in table 6.04. Continue to hold the pipe and fitting together for the duration of the cooling time specified in table 6.04.

## Socket fusion welding (continued)

### MACHINE SOCKET FUSION WELDING – Ø25mm TO Ø125mm

#### Equipment and Set-up



- Place the socket welding machine on a secure bench.

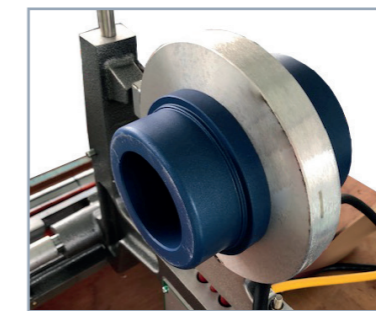

- Set the machine up, including the following steps:

- Attach the correct diameter clamps and supports. Ensuring pipe clamps are on the left and socket clamps are on the right.
- Attach the hot plate.
- Bolt the correct Type A male/female irons to the hot plate, in their correct positions. Female iron on the left, male iron on the right of the hot plate.



- Turn the machine on and allow the hot plate to reach a temperature of 260°C. When the welding device has reached temperature, re-tighten the bolts holding the male and female irons on the hot plate. **Recommendation:** Use safety gloves and sleeves, using an Allen Key to tighten.



- While waiting for the hot plate to reach the required temperature, adjust the pipe and fitting clamps to approximately the correct level, using the pipe and fittings as a guide.

## Socket fusion welding (continued)

### Welding process step-by-step

1. Set the machine cam to the correct  $\varnothing$  size to be welded.
2. Mount the pipe and socket into the machine. Ensure the pipe positioning stop is engaged prior to mounting the pipe and socket into the machine. Socket (right) and pipe (left).
3. Wind the clamp beds together to the machine stop. Adjust the pipe so that the cut face just touches the socket and they are aligned to each other. Tighten clamps to firmly grip the product to be welded (without causing distortion).
4. Wind the clamp beds apart. Using an isopropyl alcohol based cleaner, wipe the pipe spigot and fitting socket to be welded.
5. Pull out the pipe positioning stop. Manoeuvre the hotplate into its welding position.
6. Wind the clamp beds together until the socket reaches the shoulder of its iron. Lightly maintain pressure so that they do not back off and keep the weld surface on the irons for the relevant heating time, as shown in table 6.04.
7. Once the heating time has lapsed, wind the clamp beds fully apart and push the hot plate back to its starting position.
8. Wind the clamp beds back together, the pre-set cam will insert the pipe into the socket at the pre-set depth.
9. Lightly maintain pressure on the machine bed to prevent the welding surfaces from separating.

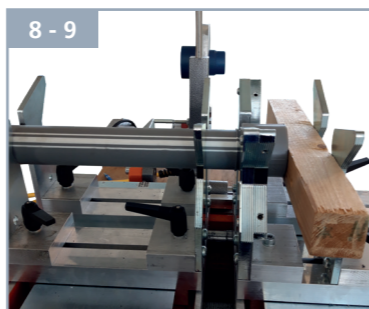
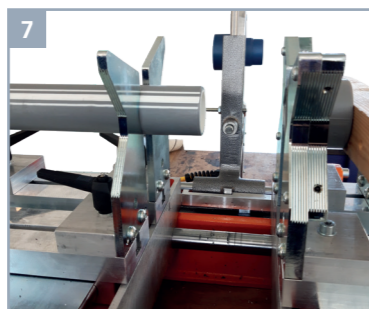
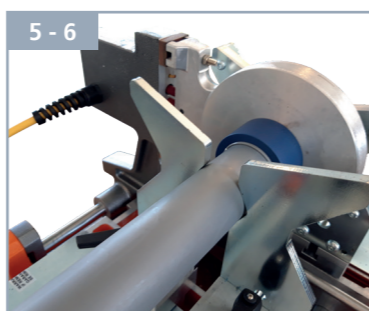
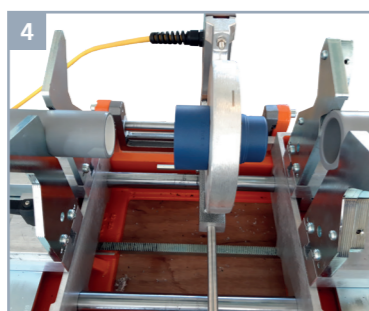
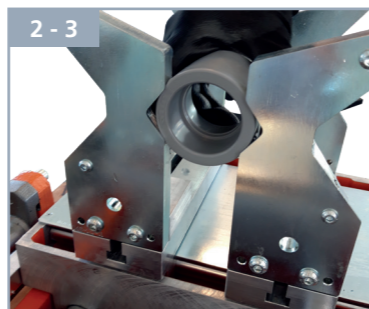

10. If available, lock the bed off or hold in position and leave for the required cooling time listed in table 6.04.
11. Once the cooling time has elapsed, remove the welded piece from the machine bed.

## Butt fusion welding

### BUTT FUSION WELDING – $\varnothing 160\text{mm}$ TO $\varnothing 315\text{mm}$

Butt fusion welding is a process by which the ends of the pipes to be jointed are heated and then pressed together under a known force for a pre-determined amount of time. This forms a homogenous weld throughout the butt weld surface.

### Equipment and set-up

There are a number of butt fusion machines available from multiple manufacturers, ranging from manual to fully-automatic operation. The welding machine used should be suitable for use with MecFlow Fusion pipes and fittings, with a maximum SDR (diameter to wall thickness ratio) of 7.5. The machine must be placed in an environment with a stable temperature, without exposure to high winds. The equipment must:

1. Be set up on a secure base, at a comfortable working height.
2. Have the clamps set correctly for the diameter of the pipe that has to be welded.
3. Have a planner which can be used to square up both mating surfaces prior to heating.

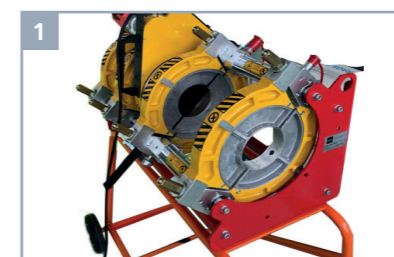

- Note:** Example shown is on a counter-weight balance.
4. Have a hot plate which can be introduced to the mating surfaces throughout the heating cycle of the process. The hot plate must be capable of reaching  $210^{\circ}\text{C} \pm 10^{\circ}\text{C}$ .
  5. Feature a mechanical hand ( $\varnothing 20\text{mm}$  to  $\varnothing 125\text{mm}$ ) or hydraulic ( $\varnothing 160\text{mm}$  to  $\varnothing 400\text{mm}$ ) drive system to move the pipe surfaces together and clamp them to the correct force for the duration of any cycles which require pressure to be applied.

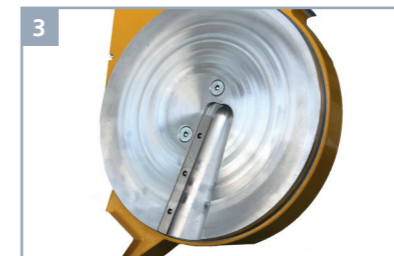

6. Include a pressure gauge to take drag and clamp pressure readings.

## Butt fusion welding (continued)

### PRE-WELDING PROCESS

1. Before switching the machine on, check the surface of the hot plate for any damage to the teflon coating. Any damaged hot plates should be replaced.
2. Clean both surfaces of the hot plate with isopropyl alcohol based cleaner (91% volume or greater).
3. Turn the machine on and allow the hot plate to reach a temperature of 210°C. Check this temperature with a thermometer before carrying out the first weld.
4. Cut the pipes to be jointed, ensuring the cuts are square.
5. While waiting for the hot plate to reach temperature, set the pipe clamps to the correct clamping force and check the function of the drive system and planing device.
6. Assemble the pipe pieces into the butt fusion machine and clamp accordingly. When working with long pipes, additional support may be required.
7. Once the pipes are clamped correctly, the drag pressure must be determined. Move the hydraulic drive and read the pressure on the pressure gauge.
8. Bring the planing device into the bed of the machine, turn on and lightly bring the pipe surfaces to the planer.
9. Plane the pipe ends until they are flat to the planing device.
10. Remove the planing device and bring the mating surfaces together. They must align with a minimum axial deflection of  $\leq 10\%$  of the wall thickness.
11. When the pipes are together, check the gap between the planed ends. This should not exceed the dimension stated in table 6.06 at any point around the mating face's circumference.



Under no circumstances must the ends of the pipe be touched or contaminated from this point forward. If they are then they must be re-planed.

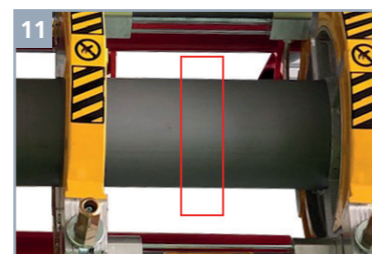
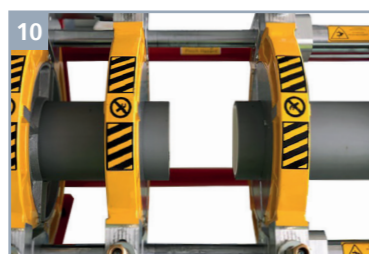

## Butt fusion welding (continued)

### BUTT WELDING PROCESS

There are a number of butt fusion machines available, each with different operation methods. The welding process should take place in a temperature stable environment above 5°C, avoiding areas of high winds. Welding should only be carried out once all pre-welding processes are completed satisfactorily.

There are five timed steps to follow for the butt fusion welding process. These timings vary depending on the diameter being welded.

#### Butt welding process step-by-step

##### STEP 1 – t1

Forming of the weld bead (under pressure).

##### STEP 2 – t2

Heating soak time (no pressure).

##### STEP 3 – t3

Removal of the heat element and bringing the mating faces together. This is a maximum time allowed for this step.

##### STEP 4 – t4

Pressure increase on the mating faces.

##### STEP 5 – t5

Cooling time (under pressure).

MAXIMUM SEPARATION OF THE PIPES PREPARED TO BE WELDED	
PIPE OD mm	SEPARATION mm
$\leq 355$	0.5

Table 6.06

Diagram 6.07

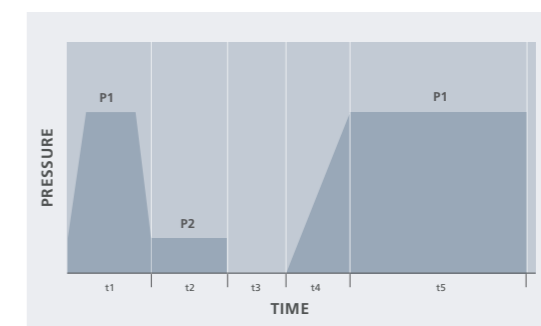

PARAMETERS OF BUTT WELDING ACCORDING TO DVS 2207-11					
PIPE THICKNESS mm	PROTRUSION OF THE INITIAL WELDING CORD mm	HEATING TIME t2 Seconds	TIME FOR REMOVING THE PLATE t3 Seconds	TIME FOR REACHING PRESSURE t4 Seconds	COOLING TIME t5 minutes
< 4,5	0.5	135	5	6	6
4, 5 – 7	0.5	135 – 175	5 – 6	6 – 7	6 – 12
7 – 12	1.0	175 – 245	6 – 7	7 – 11	12 – 20
12 – 19	1.0	245 – 330	7 – 9	11 – 17	20 – 30
19 – 26	1.5	330 – 400	9 – 11	17 – 22	30 – 40
26 – 37	2.0	400 – 485	11 – 14	22 – 32	40 – 55
37 – 50	2.5	485 – 560	14 – 17	32 – 43	55 – 70

Table 6.08

The values for applied pressure by  $\emptyset$  are machine-specific and the operator must familiarise themselves with the relevant tables before beginning the welding process.

## Butt fusion welding (continued)

### STEP 1 – t1

The purpose of this step is to create a bead of material around the circumference of both mating surfaces (this is not the finished bead). The size of this bead is machine-specific and the operator should familiarise themselves with the machine instructions before beginning.

1. Ensure all pre-welding process steps are complete.
2. Bring the mating surfaces to the hot plate and apply the relevant pressure.
3. Begin t1 time sequence.
4. On completion of t1 move to Step 2 – t2.

Diagram 6.09 – t1 Showing up of the welding cord

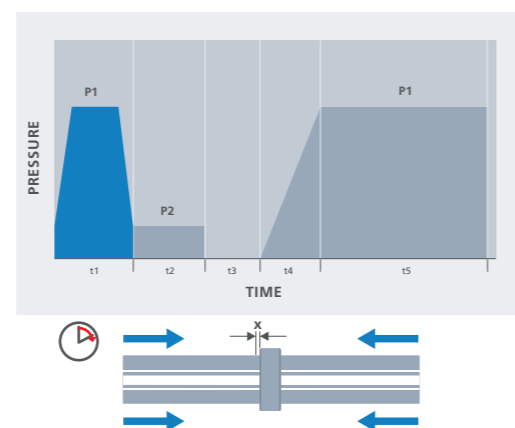

### STEP 2 – t2

1. Immediately after completing the time for t1, reduce the pressure on the mating surfaces such that the only pressure applied is to keep the mating surfaces in contact with the hot plate.
2. Begin t2 time sequence.
3. On completion of t2 move to Step 3 – t3.

Diagram 6.10 – t2 Heating

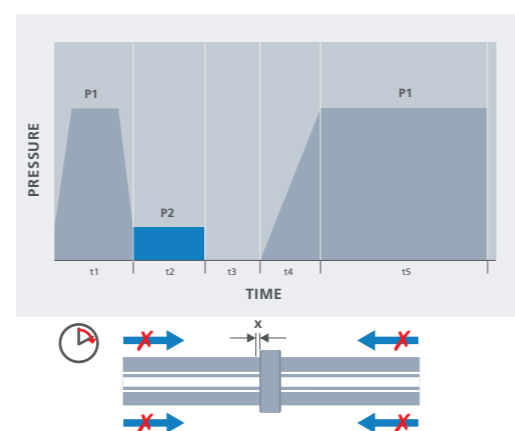

### STEP 3 – t3

**Important: This step must be completed within the specified time**

1. Immediately after completing t2, remove the mating faces from the hot plate.
2. Remove the hot plate from the machine bed.
3. Quickly bring the mating surfaces together.
4. Once the mating faces are together, move to Step 4 – t4.

Diagram 6.11 – t3 Removing the heating element

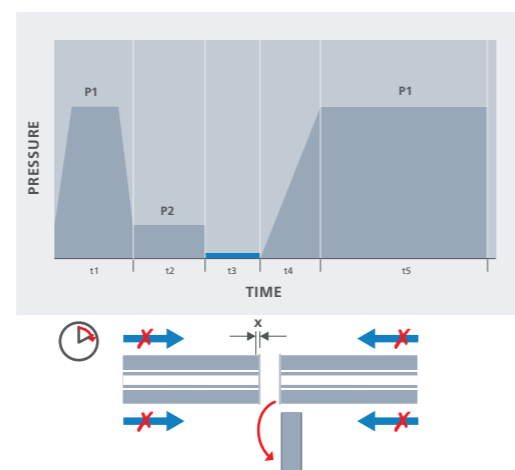

#### KEY

- Direction of pressure to be applied.
- No pressure to be applied, product to remain in contact with heat plate only.
- Heat Plate.

## Butt fusion welding (continued)

### STEP 4 – t4

1. Immediately after completing t3, apply the relevant pressure to the machine pressure, and add the drag pressure to the force established in the pre-weld phase.
2. Once the correct pressure is reached, move to Step 5 – t5.

Diagram 6.12– t4 Pressure increase

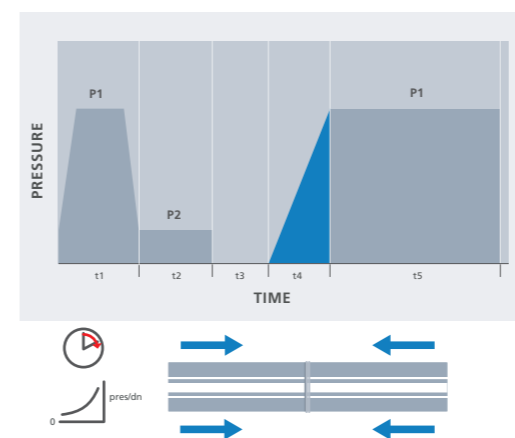

### STEP 5 – t5

1. Begin time t5 and ensure that the drive bed of the machine is secured throughout the cooling period.
2. Once the t5 time is reached, release the pressure on the mating face.
3. Once the pressure on the mating faces is released, remove the welded piece from the machine.

Diagram 6.13 – t5 Cooling

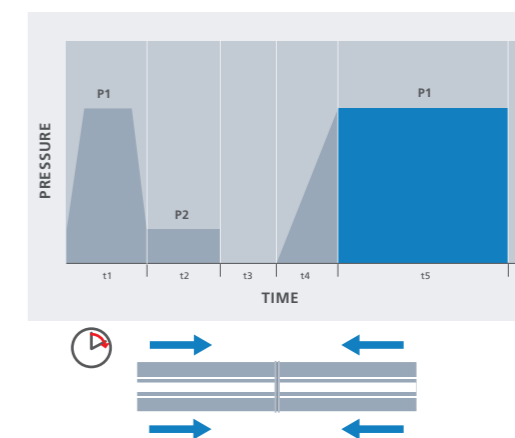

## VISUAL INSPECTION

The only non-destructive method for checking weld quality is to inspect the external bead that is formed during the process. An ideal bead is shown in diagram 6.14 (below) and graph 6.15 (opposite).

Diagram 6.14

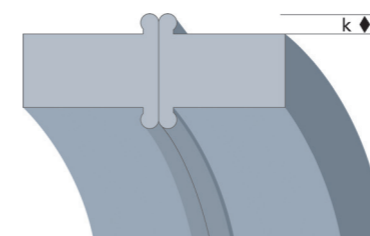

#### KEY

- Direction of pressure to be applied.
- No pressure to be applied, product to remain in contact with heat plate only.

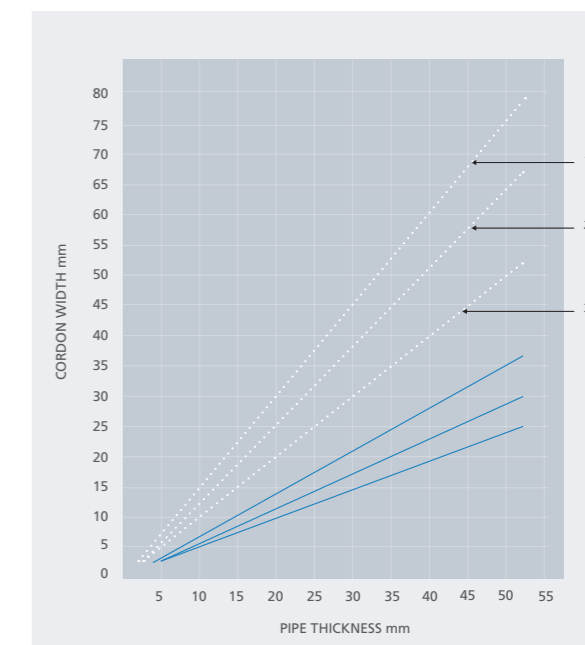

Graph 6.15

## Butt fusion welding (continued)

COMMON WELD DEFECTS					
	DEFECT	DESCRIPTION	EVALUATION		
			LEVEL 1	LEVEL 2	LEVEL 3
1		Surface cracks in a parallel or transverse direction to the weld – check the weld area, the heat-affected area and the pipe surface close to the weld.	Not allowed	Not allowed	Not allowed
2		Local or continued notches in parallel to the weld with the notch root in the core material. Causes are: Incorrect pressure adjustment Too short annealing time Too short cooling time	Not allowed	Not allowed	Not allowed
3		Notches close to the weld. Caused by: Incorrect adjustment of clamping jaws Damage during transport Incorrect weld preparation	Allowed only if $s \leq 0,5 \text{ mm}$	Allowed only if $s \leq 1,0 \text{ mm}$	Allowed only if $s \leq 2,0 \text{ mm}$
4		Misalignment of pipes Machine not set up correctly	Allowed only if $e \leq 2 \text{ mm}$	Allowed only if $e \leq 4 \text{ mm}$	Allowed only if $e \leq 5 \text{ mm}$
5		Angular misalignment of pipes Machine set up incorrectly Machine failure during weld process	Allowed only if $e \leq 1 \text{ mm}$	Allowed only if $e \leq 2 \text{ mm}$	Allowed only if $e \leq 4 \text{ mm}$
6		Sharp edges on external weld bead Incorrect welding parameters Excessive weld pressure	Not allowed	Not allowed	Not allowed
7		Irregular weld bead width Check annealing time Check weld plate for temperature Check weld pressure	Allowed values are defined in the Bead width table opposite	Allowed values are defined in the Bead width table opposite	Allowed values are defined in the Bead width table opposite
8		'Dry' joint on part or all of weld bead i.e. no fusion achieved. Contaminated hot plate Hot plate out of temperature (low and high) Time t3 too long	Not allowed	Not allowed	Not allowed
9		Hollows between the butt weld surfaces Low cooling pressure Insufficient cooling time	Not allowed	Not allowed	Not allowed
10		Contamination or gas pockets in butt weld bead Contamination during weld process Wet pipe surface during welding	Allowed isolated pores only if $s \leq 0,05s$	Allowed isolated pores only if $s \leq 0,10s$	Allowed isolated pores only if $s \leq 0,15s$

Table 6.16

## Electrofusion welding

### ELECTROFUSION WELDING – Ø20mm TO Ø315mm

It's important to note that both our standard MecFlow Fusion electrofusion couplings and unique CLICKWELD™ couplings are welded using this process.

The label also contains the welding conditions that need to be set, should the electrofusion machine require a manual set-up.

Each fitting features a barcode label that can be read by the electrofusion machine for the purpose of set-up and weld condition data storage.

### MECFLOW FUSION ELECTROFUSION COUPLINGS – Ø20mm TO Ø315mm

#### Equipment and set-up

There are several welding machines available that are suitable for welding MecFlow Fusion electrofusion couplings. The welding voltage and welding time varies by diameter. The label and barcode provide the welding parameters required. A rotary pipe scraper is also required for de-oxidation of the pipe surface before welding.

#### PRE-WELDING PROCESS

1. Cut the pipe square and use a turbo scraper to de-oxidise the pipe, up to 63mm. Above 63mm orbital planers and hand planers can be used.
2. Mark the insertion depth of the coupling on both pipe surfaces to be welded.
3. Using a cotton cloth, wipe the internal surface and ends of the scraped and de-oxidised pipes. Remove electrofusion couplings from packaging and insert the pipe.



#### CLAMPING

1. Suitable clamps should be chosen dependant on pipe diameter and location of installation. Clamps should be tightened to restrict longitudinal movement and any angular or diametric distortion during the weld process. Spider or bench based clamps are typically used for installation of the electrofusion joints.

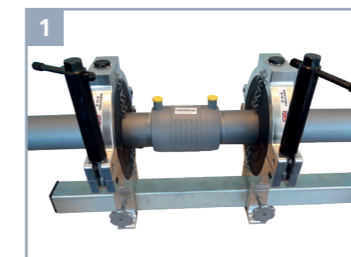

## Electrofusion welding (continued)

### WELDING PROCESS

The operator must be familiar with the sequence of the electrofusion welding machine before carrying out this step. Make sure the electrofusion machine is connected to a reliable and stable power source.

1. Insert the de-oxidised pipe ends into both sides of the coupling. Make sure the pipe ends are pushed fully to the coupling centre stop, and there is no angular deflection between the pipe and the coupling. Check that there is an air gap around the circumference of the coupling.
2. Tighten the supports/brackets around the pipe.
3. Connect the terminals of the welder to the electrofusion coupling.
4. Provided the machine is not showing an error, cycle the machine through the welding sequence, if available use a bar coding reader to scan the coupling.
5. Once the weld sequence has successfully completed, leave the welded coupling to cool down for the time indicated on the label. Do not disturb the coupling during the cooling period. Cooling time should be extended in ambient temperatures above 25°C, or when welding in strong direct sunlight.

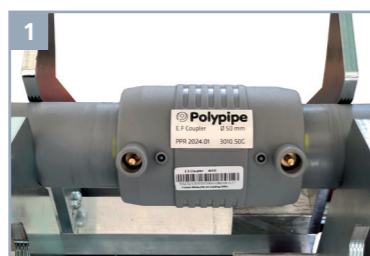

### WELD QUALITY

Providing an easily-recognised reference point, our electrofusion couplings feature visual indicators, showing that the welding process has been successful. The pictures opposite show a coupling before and after welding. Providing the indicators have risen within the coupling, the weld cycle has been successful.



Pre-weld



Post-weld

## Electrofusion welding (continued)

### CLICKWELD™ FUSION COUPLINGS – Ø50mm TO Ø125mm

The CLICKWELD™ jointing method is different to the MecFlow Fusion welding process, in that the electrofusion element is a spigot that is inserted into the socket of the CLICKWELD™ fittings. The CLICKWELD™ fittings are supplied with protective packaging that should be removed and each fitting spigot and socket wiped using an isopropyl alcohol based cleaner (91% volume or greater) prior to welding. When welding in-situ, the CLICKWELD™ spigot and fitting are held together by the patented clipping mechanism, so supports and brackets can be tightened post-weld.

#### Equipment and set-up

There are several welding machines available that are suitable for welding CLICKWELD™ electrofusion couplings. The welding voltage and the welding time varies by diameter, the label on each fitting should be checked for welding parameters.

### PRE-WELDING PROCESS



1. Remove the protective packaging from the CLICKWELD™ coupling, wipe both the spigot and socket with an isopropyl alcohol based cleaner (91% volume or greater).



2. Check that the spigot/socket is free of any mechanical damage or defects. Using an isopropyl based cleaner (91% volume or greater), clean the spigot and socket to be welded. Insert the spigot into the socket, clicking the clips of the CLICKWELD™ coupling spigot into the grooves of the socket fitting.

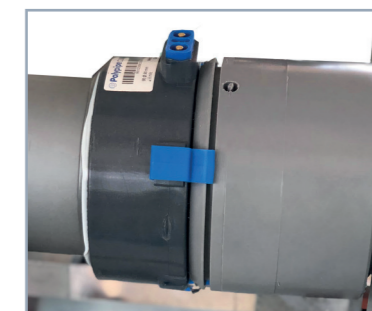

3. Check that the joint has no angular deflection.

## Electrofusion welding (continued)

### WELDING PROCESS

The operator must be familiar with the sequence of the electrofusion welding machine before carrying out this step. Make sure the electrofusion machine is connected to a reliable and stable power source.

1. Check that all clips are fully engaged.
2. Connect the terminals of the welder to the electrofusion coupling.
3. Enter the welding parameters into the electrofusion welding machine (if available use a barcode reader to scan the coupling). Once complete, cycle the machine through the welding sequence.
4. Once the weld sequence has successfully completed, leave the welded coupling to cool down for the time indicated on the label. Do not disturb the coupling during the cooling period. Cooling time should be extended in ambient temperatures above 25°C, or when welding in strong direct sunlight.

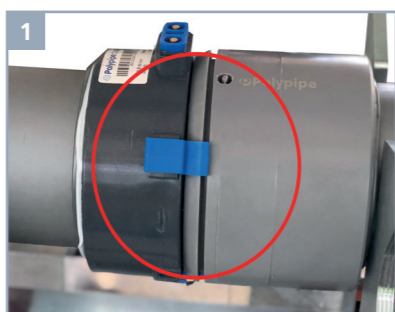

# 7. Installation

It's vital that the MecFlow Fusion system is installed correctly to maximise its performance over its service life.

The following installation methods are designed to ensure performance over a number of applications. For other applications, we recommend that you contact the Polypipe Advantage team on 01622 392215.

## PIPE WEIGHTS

Pipe weights and filled pipe weights are shown in the table below.

PIPE WEIGHTS		
PIPE Ø	PIPE Empty (kg/lm)	PIPE Full (kg/lm)
20	0.14	0.30
25	0.21	0.47
32	0.35	0.78
40	0.39	1.23
50	0.60	1.92
63	0.96	3.05
75	1.36	4.32
90	1.96	6.22
110	2.92	9.28
125	3.77	11.99
160	6.10	19.64
200	9.66	30.69
250	15.09	47.96
315	23.96	76.14

Table 7.01

## SYSTEM BRACKETING – GENERAL

- The brackets used to install the MecFlow Fusion system must be capable of supporting the pipe weights as shown in Table 7.01.
- Brackets must be rubber lined to prevent the pipe surface from being damaged by the bracket ring. For noise-sensitive operations the use of isophonic brackets is recommended.
- Guide brackets and anchor brackets should be placed on the system in accordance with 7.02 and 7.03.
- Guide brackets must control the axial movement of the pipe in the direction of the applied thermal movement forces.
- Anchor brackets lock the pipe into position, and should be robust enough to counteract any thrust forces applied to the pipe due to thermal movement.

## System bracketing

Brackets should be connected to the substrate using threaded rod or another suitable fixing method. If the threaded rod is used, the rod length should be kept to a minimum to prevent the bracket fixing from bending or swinging when the system is in operation.

## BRACKET DISTANCES – GENERAL

HORIZONTAL BRACKET DISTANCES			
PIPE OD cm	20°	50°	70°
	cm	cm	cm
20	90	85	70
25	105	95	80
32	120	110	95
40	125	115	100
50	145	135	120
63	165	155	135
75	175	160	140
90	185	170	145
110	200	170	150
125	205	175	155
160	210	180	160
200	220	190	170
250	225	200	175
315	230	205	185
400	210	220	195
500			

Table 7.02

VERTICAL BRACKET DISTANCES			
PIPE OD cm	20°	50°	70°
	cm	cm	cm
20	117	111	91
25	137	124	104
32	156	143	124
40	163	150	130
50	189	176	156
63	215	202	176
75	228	208	182
90	241	221	189
110	260	221	195
125	267	228	202
160	273	234	208
200	286	247	221
250	293	260	228
315	299	267	241
400	325	286	254
500			

Table 7.03

## Thermal movement

### CONTROL OF THERMAL MOVEMENT

Due to the microfibre additive featured in the MecFlow Fusion system, expansion and contraction due to temperature change is significantly reduced. However, it is still important to control thermal movement to counteract the forces generated. This can be achieved using various installation techniques and a combination of anchor and guide brackets.

**MecFlow Fusion coefficient of thermal expansion: 0.04mm/m/°C**

The general equation for calculating thermal movement in a system (or part of a system) is listed below.

The value for 'Δt' should be taken as the difference between the ambient temperature at the time of system installation and the fluid temperature once the system is operating.

As the pipe must generally be at the ambient temperature prior to commissioning, ambient temperature should not be taken into account during the operation of the system.

#### Worked Example

Calculate the thermal movement seen in the pipe below.

#### Equation 1

$$\Delta L = L \times \lambda \times \Delta t$$

ΔL = Calculated thermal movement

L = Length

λ = Coefficient of thermal expansion for MecFlow Fusion

Δt = Expected temperature difference

System pipe length = 6m

Temperature difference = 20°C

L = 6m, Δt = 20°C, λ = 0.04mm/m/°C

ΔL = L x λ x Δt

ΔL = 6 x 0.04 x 20

ΔL = 4.8mm

The table below shows the rate of thermal movement by pipe length for a given change in temperature.

LENGTH (L)	Δt								
	1°	10°	20°	30°	40°	50°	60°	70°	80°
	LINEAR EXPANSION mm								
1m	0.0	0.4	0.8	1.2	1.6	2.0	2.4	2.8	3.2
3m	0.1	1.2	2.4	3.6	4.8	6.0	7.2	8.4	9.6
5m	0.2	2.0	4.0	6.0	8.0	10.0	12.0	14.0	16.0
10m	0.4	4.0	8.0	12.0	16.0	20.0	24.0	28.0	32.0
15m	0.6	6.0	12.0	18.0	24.0	30.0	36.0	42.0	48.0
20m	0.8	8.0	16.0	24.0	32.0	40.0	48.0	56.0	64.0
25m	1.0	10.0	20.0	30.0	40.0	50.0	60.0	70.0	80.0
30m	1.2	12.0	24.0	36.0	48.0	60.0	72.0	84.0	96.0
35m	1.4	14.0	28.0	42.0	56.0	70.0	84.0	98.0	112.0
40m	1.6	16.0	32.0	48.0	64.0	80.0	96.0	112.0	128.0
45m	1.8	18.0	36.0	54.0	72.0	90.0	108.0	126.0	144.0
50m	2.0	20.0	40.0	60.0	80.0	100.0	120.0	140.0	160.0

Table 7.04

### THERMAL MOVEMENT – CONTROL METHODS

The following methods provide thermal movement control for the MecFlow Fusion system.

- Deflection leg
- Expansion loop
- Pre-stressing
- Sliding tee's
- Fully locked (anchored)

### DEFLECTION LEG

Deflection leg control is where a bend in the system is allowed to 'flex' in a controlled manner, so as to allow for thermal movement (see diagram 7.05).

If this method is used it is essential to place anchor brackets at distances 'L' and 'L<sub>b</sub>' from the bend point. Distance 'L<sub>b</sub>' must be calculated to take into account the distance 'L', the pipe diameter, and the system temperature conditions.

Diagram 7.05

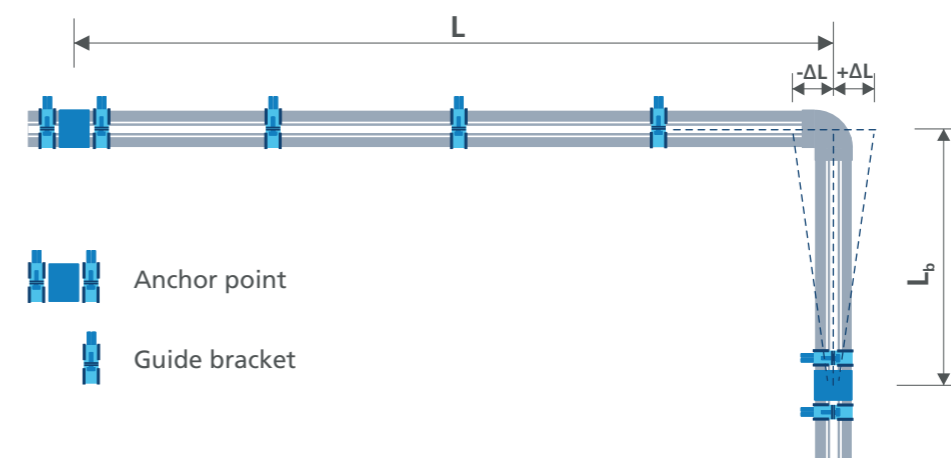

The equation to calculate distance 'L<sub>b</sub>' is given as:

#### Equation 2

$$L_b = \lambda \times \sqrt{d \times \Delta L}$$

λ = MecFlow Fusion coefficient of thermal movement

d = Outside diameter of pipework

ΔL = Calculated thermal movement for distance L

## Thermal movement (continued)

The table below indicates the distance 'L<sub>b</sub>' for a given thermal movement by pipe diameter.

PIPE OD mm	LINEAR EXPANSION mm											
	10	20	30	40	50	60	70	80	90	100	110	120
	L <sub>b</sub> mm											
20	0.57	0.80	0.98	1.13	1.26	1.39	1.50	1.60	1.70	1.79	1.88	1.96
25	0.63	0.89	1.10	1.26	1.41	1.55	1.67	1.79	1.90	2.00	2.10	2.19
32	0.72	1.01	1.24	1.43	1.60	1.75	1.89	2.02	2.15	2.26	2.37	2.48
40	0.80	1.13	1.39	1.60	1.79	1.96	2.12	2.26	2.40	2.53	2.65	2.77
50	0.89	1.26	1.55	1.79	2.00	2.19	2.37	2.53	2.68	2.83	2.97	3.10
63	1.00	1.42	1.74	2.01	2.24	2.46	2.66	2.84	3.01	3.17	3.33	3.48
75	1.10	1.55	1.90	2.19	2.45	2.68	2.90	3.10	3.29	3.46	3.63	3.79
90	1.20	1.70	2.08	2.40	2.68	2.94	3.17	3.39	3.60	3.79	3.98	4.16
110	1.33	1.88	2.30	2.65	2.97	3.25	3.51	3.75	3.98	4.20	4.40	4.60
125	1.41	2.00	2.45	2.83	3.16	3.46	3.74	4.00	4.24	4.47	4.69	4.90
160	1.60	2.26	2.77	3.20	3.58	3.92	4.23	4.53	4.80	5.06	5.31	5.54
200	1.79	2.53	3.10	3.58	4.00	4.38	4.73	5.06	5.37	5.66	5.93	6.20

Note: Linear expansion is calculated using equation 1 for the distance 'L'.

Table 7.06

### EXPANSION LOOPS

Expansion loop control is where a loop in the system is allowed to 'flex' in a controlled manner, allowing thermal movement (see diagram 7.07). If this method is used it is essential to place anchor brackets at distances 'L' and 'L<sub>b</sub>' from the bend point. Distance 'L<sub>b</sub>' must be calculated, take into account the distance 'L', the pipe diameter, and the system temperature conditions.

'L<sub>b</sub>' should be calculated in accordance with equation 2. 'L<sub>2</sub>' should be calculated using equation 3; the minimum 'L<sub>2</sub>' value is 210mm.

Table 7.06 above, gives the distance 'L<sub>b</sub>' for a given thermal movement by pipe diameter.

#### Equation 3

$$L_{2min} = 2 \times \Delta L \times SD$$

$\Delta L$  = Calculated thermal movement for distance L

SD = Safety distance = 150mm

Diagram 7.07

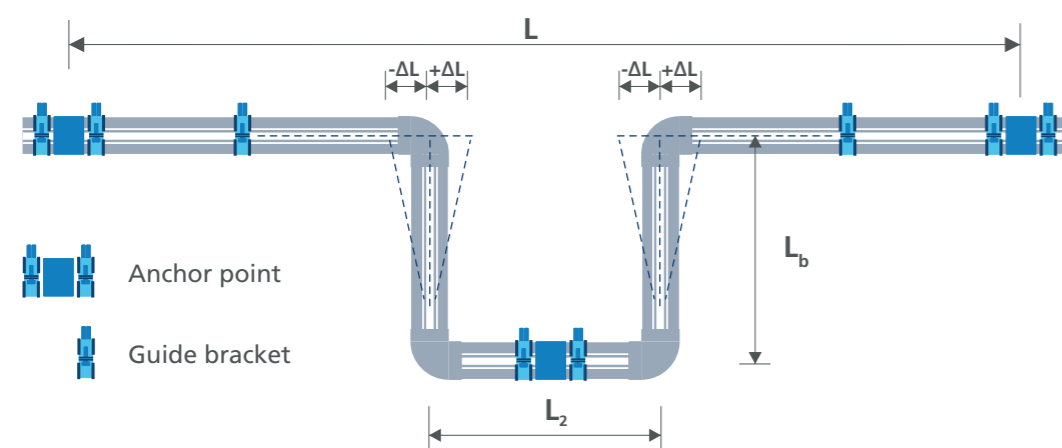

### PRE-STRESSING

The pre-stressing method is useful in instances where space is limited, and the distance 'L<sub>b</sub>' for either the deflection leg or expansion loop method needs to be kept to a minimum. The system is installed with pre-stressed elements in the opposite direction to the intended thermal movement, ensuring that when the system is commissioned thermal movement is limited, or in certain cases is eliminated.

For both deflection legs and expansion loops the distance 'L<sub>bps</sub>' is calculated using equation 4.

#### Equation 4

$$L_b = \lambda \times \sqrt{d \times \Delta L} \times 2$$

The distance 'L<sub>2</sub>' is calculated as per standard expansion loops using equation 3. Again, the minimum distance is 150mm.

Diagram 7.08

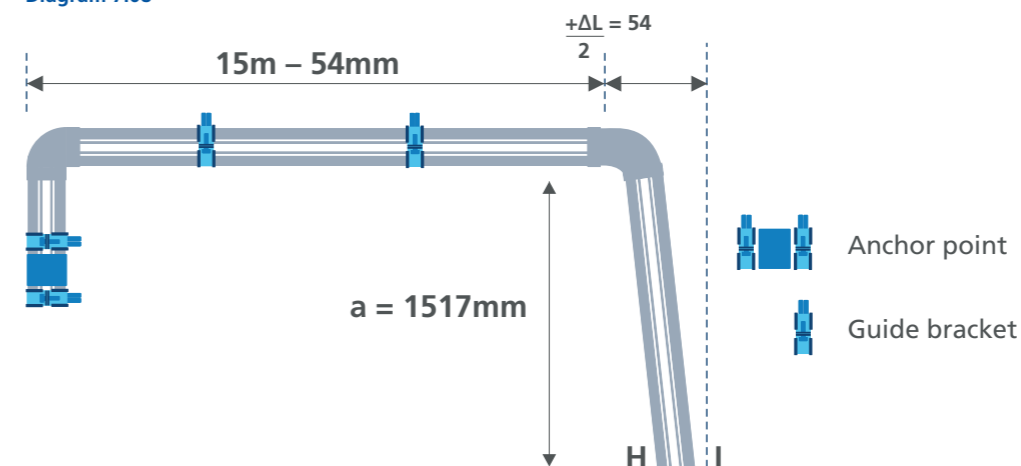
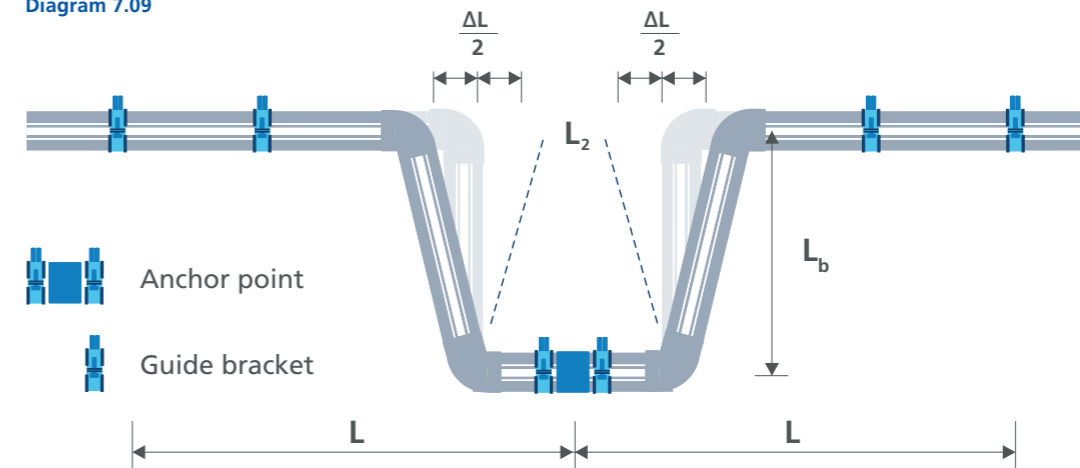

Diagram 7.09



## Thermal movement (continued)

The table below indicates the distance 'L<sub>bps</sub>' for a given thermal movement by pipe diameter.

PIPE OD mm	LINEAR EXPANSION mm											
	10	20	30	40	50	60	70	80	90	100	110	120
	L <sub>bps</sub> mmw											
20	0.40	0.57	0.69	0.80	0.89	0.98	1.06	1.13	1.20	1.26	1.33	1.39
25	0.45	0.63	0.77	0.89	1.00	1.10	1.18	1.26	1.34	1.41	1.48	1.55
32	0.51	0.72	0.88	1.01	1.13	1.24	1.34	1.43	1.52	1.60	1.68	1.75
40	0.57	0.80	0.98	1.13	1.26	1.39	1.50	1.60	1.70	1.79	1.88	1.96
50	0.63	0.89	1.10	1.26	1.41	1.55	1.67	1.79	1.90	2.00	2.10	2.19
63	0.71	1.00	1.23	1.42	1.59	1.74	1.88	2.01	2.13	2.24	2.35	2.46
75	0.77	1.10	1.34	1.55	1.73	1.90	2.05	2.19	2.32	2.45	2.57	2.68
90	0.85	1.20	1.47	1.70	1.90	2.08	2.24	2.40	2.55	2.68	2.81	2.94
110	0.94	1.33	1.62	1.88	2.10	2.30	2.48	2.65	2.81	2.97	3.11	3.25
125	1.00	1.41	1.73	2.00	2.24	2.45	2.65	2.83	3.00	3.16	3.32	3.46
160	1.13	1.60	1.96	2.26	2.53	2.77	2.99	3.20	3.39	3.58	3.75	3.92
200	1.26	1.79	2.19	2.53	2.83	3.10	3.35	3.58	3.79	4.00	4.20	4.38

Note: Linear expansion is calculated using equation 1 for the distance 'L'.

Table 7.10

### SLIDING T

The Sliding T is a similar method to the deflection leg for controlling thermal movement. The distance 'L' is used to determine the thermal movement to be controlled using equation 1, and the distance 'L<sub>b</sub>' is determined using equation 2. This method cannot be configured as a pre-stressed solution.

Diagram 7.11 indicates the distance 'L<sub>b</sub>' for a given thermal movement by pipe diameter.

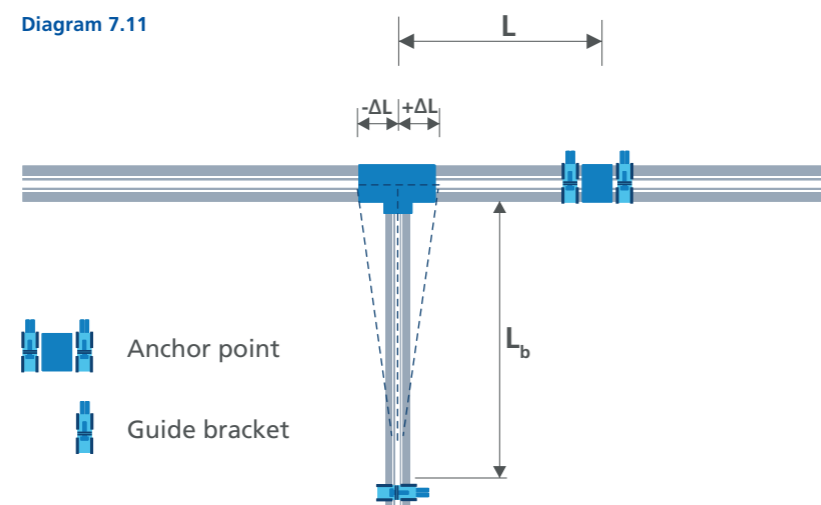

Compensating for changes in length using an expansion leg, 'L<sub>b</sub>'

### FULLY LOCKED SYSTEM

The fully locked system is ideal for BCWS and CWS service risers as there is minimal thermal movement to control. The fully locked system relies on anchor points placed at each floor level of the riser which effectively 'locks' the axial thermal movement of the system. As the system is locked there is no movement acting on any branches in the section of riser between the two anchor points.

The maximum distance between two anchor points is 3 metres. Guidance on how to create an anchor point is given in diagram 7.12. Anchor brackets should be close coupled to the supporting substrate, and if threaded rod is being used it must be capable of supporting the bracket in position. Rod size should be at least M10 for sizes up to Ø160mm, and M16 for sizes above Ø160mm.

Guide brackets are also required to support the pipe, and these distances can be referenced in table 7.03 – vertical bracket distances.

Diagram 7.12

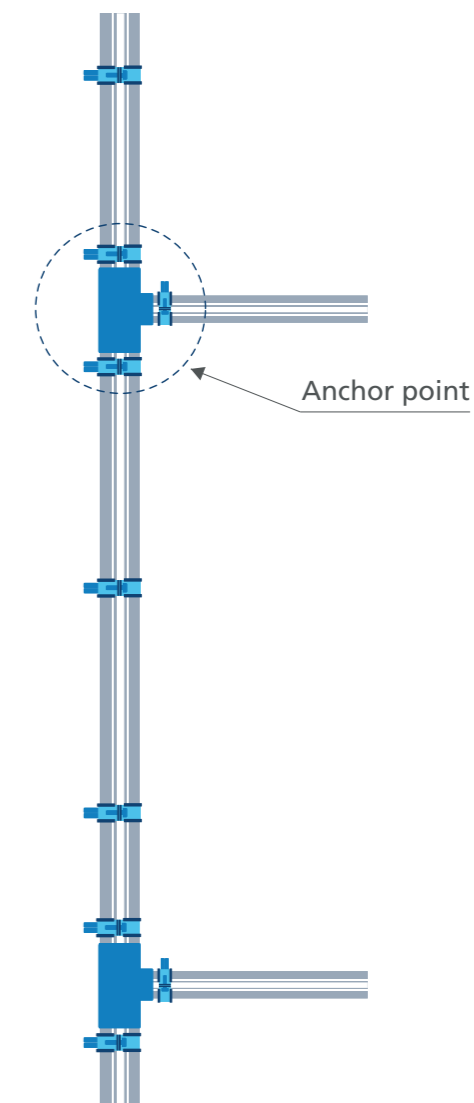

## Thermal movement (continued)

### ANCHOR POINTS

Diagram 7.13 below shows how to create a horizontal/vertical anchor point. Maximum threaded bar length: 100mm.

Diagram 7.13

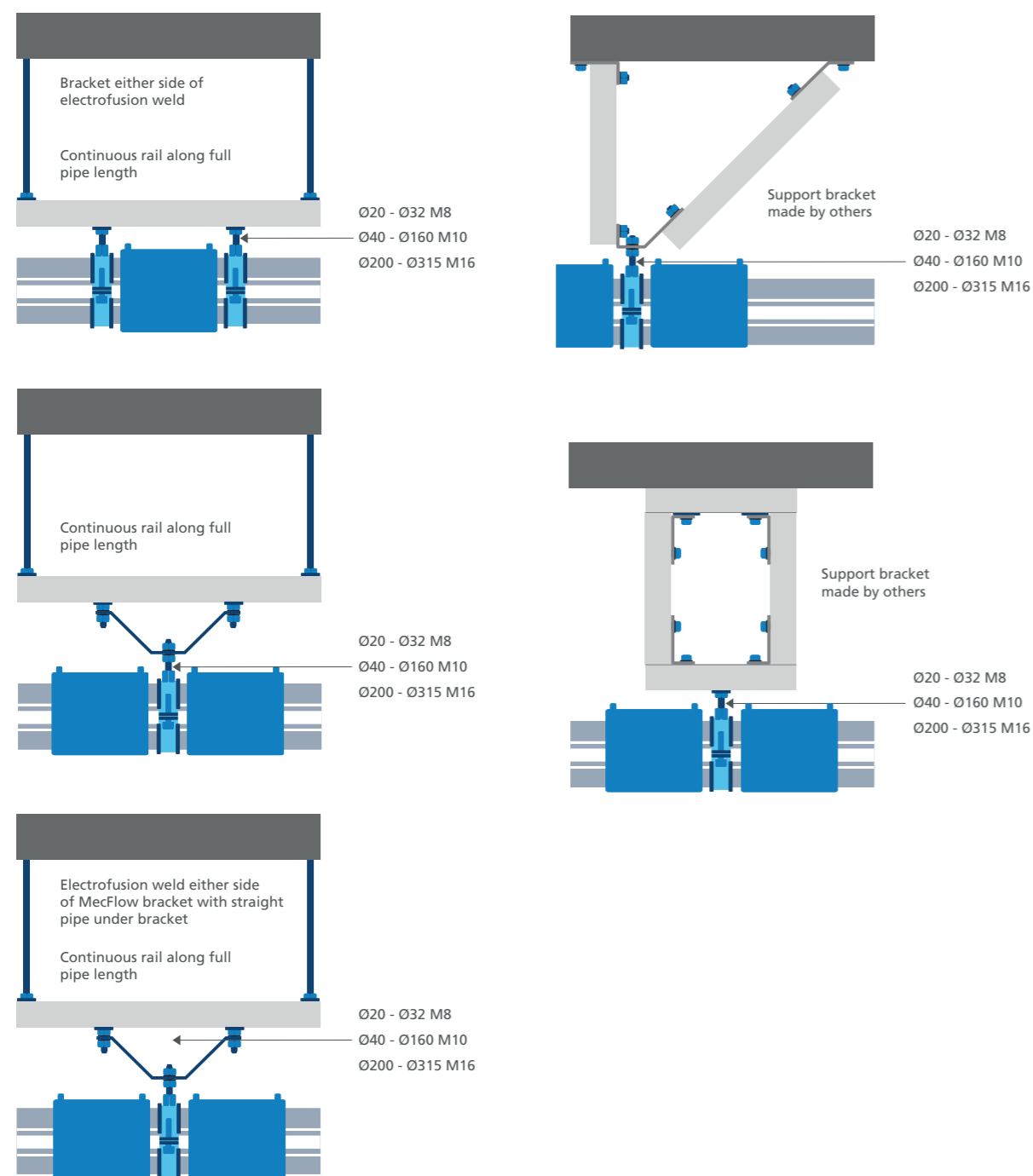

### COMPENSATORS

Standard, 'off-the-shelf' compensators must not be used within the MecFlow Fusion system.

### FLOOR/WALL PENETRATIONS

In instances where MecFlow Fusion pipes penetrate floors and walls, care must be taken to protect the surface of the pipe from any mechanical damage. This is achieved by sleeving the pipe with protection (insulation material) throughout the penetration. For fire rated compartments see the section on fire compartmentation.

### BUILDING EXPANSION JOINTS

Where the MecFlow Fusion system crosses building expansion joints, care must be taken to protect the system from excessive building movement. There are several installation solutions available, and the Polypipe Advantage team are on hand to offer technical guidance and identify the best solution for your project; dependent on the direction and extent of the thermal movement.

### TRACE HEATING/HEAT TAPE

Both trace heating and heat tapes can be used on the MecFlow Fusion system. The products used must be checked with the manufacturer as being suitable for plastic pipe, and the surface temperature of the MecFlow system must not exceed 70°C at any point. Care must be taken in both the design and installation of these external heat sources.

## Thermal movement (continued)

### FIRE COMPARTMENTATION

Although the MecFlow Fusion system has an excellent fire rating classification, the system must be considered as combustible for the purposes of compliance to UK Building Regulation B. With this in mind, where MecFlow Fusion pipes of nominal diameter  $\geq 40\text{mm}$  pass through a fire compartment floor or wall, the penetration must be protected with a suitable fire protection product.

Diagram 7.14

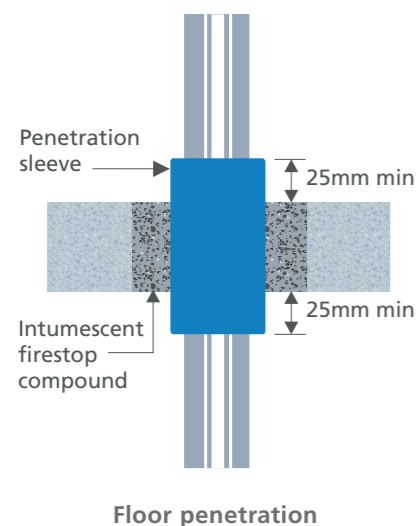

Diagram 7.15

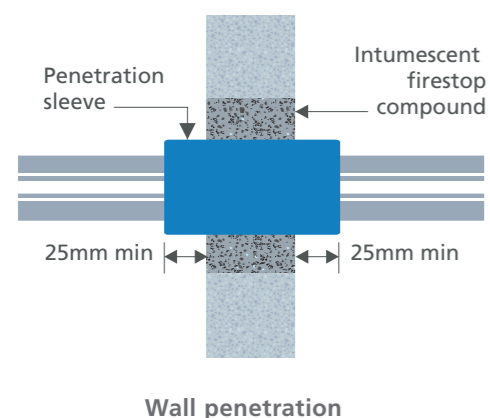
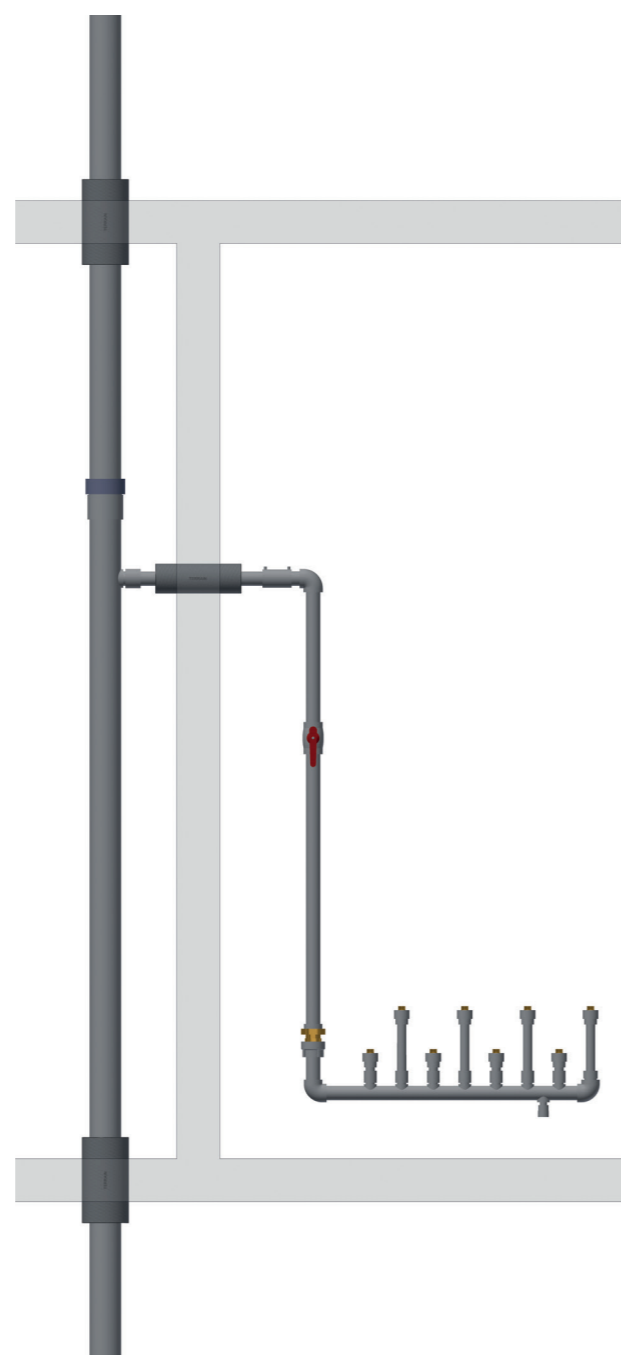

Diagram 7.16



### INSULATION

The MecFlow Fusion system is compatible with all common pipe insulation materials. Insulation thickness should be selected in accordance with Building Regulations, design standards and industry guides, such as the Domestic Heating Compliance Guide BS 5422 and the TIMSA Guidance for Achieving Compliance with Part L of the Building Regulations.

### CONNECTION TO OTHER MATERIALS

Connection to other materials can be achieved using the MecFlow Fusion range of threaded fittings, and for larger diameters, flanged connections.

Threaded connectors and unions are available in both female and male connections, straight and elbow, from 20mm to 1/2" BSP up to 110mm to 4" BSP. Please check literature for available combinations of size and shape.

Thread forms are manufactured to the following standards:

#### Threaded Connections

BS EN 10226-1:2004 – Pipe threads where pressure tight joints are made on the threads. Taper external threads and parallel internal threads. Dimensions, tolerances and designation.

#### Unions

BS EN ISO 228-1:2003 – Pipe threads where pressure-tight joints are not made on the threads. Dimensions, tolerances and designation.

#### Flanged Connections

MecFlow Fusion flanged connections are available in PN16 and PN25 ratings. The stub flanges, backing rings, blanking flanges and seals are available from 40mm to 315mm to suit the requirements of the installation.

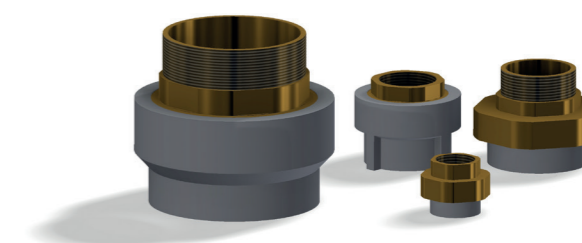
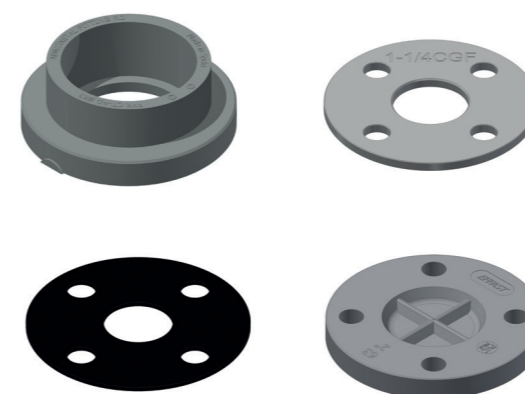

MAXIMUM WATER TEMPERATURE	VELOCITY		MAXIMUM WATER VELOCITY
	20-32mm	40-250mm	
70°C	14 bar	9 bar	1.50m/s

Table 7.17

### MECFLOW FUSION CONNECTED TO COPPER SYSTEMS

Under certain conditions, by-products of copper in water systems can cause a reaction in the MecFlow Fusion material. For MecFlow Fusion pipes where copper is present in heating circuits at 70°C, the following max pressures and velocities shown in Table 7.17, should be observed.

Although brass is an alloy of copper and zinc, there is little risk of significant oxidation in threaded brass fittings, therefore these can be discounted from the above.

# 8. Chemical resistance

The use of thermoplastic pipe systems within the commercial market is now widespread. Thermoplastics have replaced traditional materials such as steel, ductile iron and copper. Because of this diversity of use, it is essential that the most suitable plastic material is matched to its proposed application.

This section will provide a guide to compatible material selection. The information within this section has been collated from tests carried out by both national and international standards organisations (ISO/TR10358) as well as tests performed by independent test houses.

The tests were based on the use of pure chemicals. For mixed chemicals, we would advise that pilot tests should be undertaken in order to ascertain the resistance of the material under these circumstances.

## PIPE JOINTS

Electrofusion joints are regarded as generally having the same chemical resistance as the material itself. However, the jointing process can leave a certain amount of residual stress within the joint.

## SEALS AND SEAT MATERIALS

The working life of seals and seat materials is often different from that of the pipe system and greatly dependent on the working conditions involved.

Tables 8.01 and 8.02 outline their resistance.

SEAL AND SEAT MATERIAL	
MATERIAL TYPE	RESISTANCE
EDPM-Ethylene Propylene Rubber	Satisfactory resistance to most aggressive chemicals, not suitable for oils or fat
FPM-Fluorine Rubber	The most resistant of the elastomers to solvents
NBR-Nitrile Rubber	Not resistant to oxidising agents, but resists petrol and oils
PTFE-Polytetrafluoroethylene	Resists all the chemicals shown in tables

Table 8.01

TERMINOLOGY FOR CHEMICAL RESISTANCE TABLES	
SYMBOL/TERM	DESCRIPTION
✓	Resistant
○	Conditionally resistant
✗	Not recommended
-	No test data available
Technical grade	Technically pure
Saturated	Media has reached its maximum absorption in water at ambient temperature, which is the point where there can be no further absorption
Aqueous	A solution below maximum absorption, expressed as a percentage (%) of saturation (concentration)
Suspension	Insoluble or partially soluble solid carried in an aqueous base normally prepared at ambient temperature
Commercial Proprietary Industrial	Self explanatory, grades of chemical named brands in general use

Table 8.02

## Chemical resistance – table 8.03

MecFlow Fusion is made from PP-RCT, please follow the column labeled Polypropylene.

CHEMICAL	CONCENTRATION	MATERIAL °C																							
		PVCu				ABS				PE				POLYPROPYLENE				EPDM				FPM			
		20	40	60		20	40	60		20	40	60		20	60	100		20	40	60		20	60	100	120
Acetaldehyde	40% aqueous solution	○	✗	-		✗	-	-		✓	✓	○		✓	○	○		✓	○	○		✓	○	-	-
Acetaldehyde	Technically pure	✗	-	-		✗	-	-		✓	○	-		○	✗	-		✓	○	✗		○	✗	-	-
Acetic acid	50% Aqueous	✓	✓	○		✗	-	-		✓	✓	✓		✓	✓	✓		✓	○	-		○	-	-	-
Acetic acid	Technically pure glacial	○	✗	-		✗	-	-		✓	✓	○		✓	✓	○		✓	○	-		✗	-	-	-
Acetic acid anhydride	Technically pure	✗	-	-		✗	-	-		✓	○	-		✓	-	-		○	-	-		✗	-	-	-
Acetic acid ethylester		✗	-	-		✗	-	-		✓	-	-		✓	-	-		✓	-	-		○	-	-	-
Acetic acid isobutyl ester	Technically pure	✗	-	-		✗	-	-		✓	-	-		✓	-	-		✓	-	-		✗	-	-	-
Acetone	Up to 10% aqueous	✗	-	-		○	-	-		✓	✓	✓		✓	✓	✓		✓	✓	✓		○	✗	-	-
Acetone	Technically pure	✗	-	-		✗	-	-		✓	✓	✓		✓	✓	-		✓	✓	✓		✗	-	-	-
Acetonitrile	100%	✗	-	-		✗	-	-		○	-	-		○	-	-		○	-	-		✗	-	-	-
Acetophenone	100%	✗	-	-		✗	-	-		○	-	-		○	-	-		✓	-	-		✗	-	-	-
Acrylic acid methyl ester	Technically pure	✗	-	-		✗	-	-		○	-	-		✗	-	-		○	-	-		-	-	-	-
Acrylicethyl	Technically pure	✗	-	-		✗	-	-		○	-	-		✗	-	-		○	-	-		✗	-	-	-
Acrylonitrile	Technically pure	✗	-	-		✗	-	-		✓	✓	✓		✓	-	-		✓	✓	○		○	✗	-	-
Adipic acid	Saturated, aqueous	✓	✓	✗		✗	-	-		✓	✓	✓		✓	✓	-		✓	✓	✓		✓	✓	-	-
Allyl alcohol	96%	○	✗	-		✗	-	-		✓	✓	✓		✓	○	-		✓	✓	○		○	-	-	-
Ammonia	Gaseous technically pure	✓	✓	✓		✗	-	-		✓	✓	✓		✓	✓	-		✓	-	-		✓	-	-	-
Ammonium acetate	Aqueous, all	✓	✓	○		○	-	-		✓	✓	✓		✓	✓	✓		✓	✓	✓		✓	✓	-	-
Ammoniumpersulphate		✓	✓	○		-	-	-		✓	-	-		○	-	-		✓	-	-		✓	-	-	-
Ammonium salts, aqueous inorganic	Saturated	✓	✓	✓		-	-	-		✓	✓	✓		✓	✓	-		✓	✓	✓		✓	✓	-	-
Amyl acetate	Technically pure	✗	-	-		✗	-	-		✓	✓	✓		○	✗	-		○	-	-		✗	-	-	-
Amyl alcohol	Technically pure	✓	✓	○		✗	-	-		✓	✓	✓		✓	✓	-		✓	✓	✓		○	-	-	-
Aniline	Technically pure	✗	-	-		✗	-	-		✓	○	-		✓	○	-		✓	✓	✓		○	○	-	-
Antimony trichloride	90% Aqueous	✓	✓	-		✗	-	-		✓	✓	✓		✓	✓	-		✓	-	-		✓	-	-	-
Aqua regia	Mixing ratio	✓	○	-		✗	-	-		✗	-	-		✗	-	-		✗	-	-		○	-	-	-
Arsenic acid	80% Aqueous	✓	✓	○		✓	✓	✓		✓	✓	✓		✓	✓	-		✓	✓	✓		✓	✓	✓	-
Barium salts, aqueous inorganic	Saturated	✓	✓	✓		✓	-	-		✓	✓	✓		✓	✓	-		✓	✓	✓		✓	✓	✓	-
Beer	Usual commercial	✓	-	-		✓	-	-		✓	-	-		✓	-	-		-	-	-		✓	-	-	-
Benzaldehyde	Saturated, aqueous	✗	-	-		✗	-	-		✓	✓	○		✓	-	-		✓	✓	○		✓	✓	-	-
Benzene	Technically pure	✗	-	-		✗	-	-		○	○	-		○	-	-		✗	-	-		✓	-	-	-
Benzene sulfonic acid	Technically pure	✓	-	-		-	-	-		✓	✓	○		✓	○	-		✓	✓	○		✓	-	-	-

KEY: – NO DATA ✗ NOT RECOMMENDED ○ CONDITIONALLY RESISTANT ✓ RESISTANT

The information in these tables has been supplied by other reputable sources and is to be used ONLY as a guide in selecting equipment for appropriate chemical compatibility. Before permanent installation, test the equipment with the chemicals and under the specific conditions of your application. Ratings of chemical behaviour listed in this chart apply to a 48-hr exposure period, we have no knowledge of possible effects beyond this period. We do not warrant (neither express or implied) that the information in this chart is accurate or complete or that any material is suitable for any purpose.

Chemical resistance – table 8.04

MecFlow Fusion is made from PP-RCT, please follow the column labeled Polypropylene.

CHEMICAL	CONCENTRATION	MATERIAL°C																			
		PVCu			ABS			PE			POLYPROPYLENE			EPDM			FPM				
		20	40	60	20	40	60	20	40	60	20	60	100	20	40	60	20	60	100	120	
Benzene (Gasoline)	Free of lead and aromatic compounds	✓	✓	-	✗	-	-	✓	✓	-	○	-	-	✗	-	-	✓	-	-	-	-
Benzoic acid	Aqueous, all	✓	✓	○	✓	✓	-	✓	✓	✓	✓	✓	✓	✓	-	✓	✓	○	-	-	-
Benzyl alcohol	Technically pure	○	-	-	✗	-	-	✓	✓	○	✓	○	-	✓	✓	○	✓	-	-	-	-
Beryllium salts, aqueous, inorganic		✓	✓	✓	-	-	-	✓	✓	✓	✓	✓	-	✓	✓	✓	✓	✓	-	-	-
Borax	Aqueous, all	✓	✓	○	✓	✓	-	✓	✓	✓	✓	✓	✓	✓	✓	✓	✓	✓	-	-	-
Boric acid	Aqueous, all	✓	✓	○	✓	✓	✓	✓	✓	✓	✓	✓	✓	✓	✓	✓	✓	✓	-	-	-
Bromine water	Saturated, aqueous	✓	-	-	✗	-	-	✗	-	-	✗	-	-	✗	-	-	✓	-	-	-	-
Butadiene	Technically pure	✓	-	-	✗	-	-	○	-	-	○	-	-	✗	-	-	✓	-	-	-	-
Butane	Technically pure	✓	-	-	✓	-	-	✓	-	-	✓	-	-	✗	-	-	✓	-	-	-	-
Butanediol	10% Aqueous	✓	○	-	✗	-	-	✓	✓	✓	✓	✓	-	✓	✓	✓	✓	✓	-	-	-
Butanol	Technically pure	✓	✓	○	✗	-	-	✓	✓	✓	✓	○	-	✓	✓	✓	✓	✗	-	-	-
Butyl acetate	Technically pure	✗	-	-	✗	-	-	✓	-	-	○	-	-	✓	✗	-	○	-	-	-	-
Butyl phenol p-tertiary	Technically pure	○	✗	-	✗	-	-	○	-	-	✓	-	-	✗	-	-	○	-	-	-	-
Butylene glycol	Technically pure	✓	✓	○	-	-	-	✓	✓	✓	✓	✓	-	✓	✓	✓	✓	○	-	-	-
Butylene liquid	Technically pure	✓	-	-	-	-	-	✗	-	-	✗	-	-	○	-	-	✓	-	-	-	-
Butyric acid	Technically pure	✓	-	-	✗	-	-	✓	-	-	✓	-	-	○	-	-	○	-	-	-	-
Caesium salts, aqueous inorganic	<Saturated acid	✓	✓	✓	-	-	-	✓	✓	✓	✓	✓	-	✓	✓	✓	✓	✓	-	-	-
Cadmium salts, aqueous inorganic	<Saturated acid	✓	✓	✓	-	-	-	✓	✓	✓	✓	✓	-	✓	✓	✓	✓	✓	-	-	-
Calcium acetate	Saturated	✓	✓	✓	-	-	-	✓	✓	✓	✓	✓	-	✓	✓	✓	✓	✓	-	-	-
Calcium hydroxide	Saturated aqueous	✓	✓	✓	-	-	-	✓	✓	✓	✓	✓	-	✓	✓	✓	✓	✓	✓	-	-
Calcium lactate	Saturated	✓	✓	-	-	-	-	✓	✓	✓	✓	✓	-	✓	✓	✓	✓	✓	-	-	-
Calcium salts, aqueous, inorganic	Saturated acid	✓	✓	✓	✓	✓	-	✓	✓	✓	✓	✓	-	✓	✓	✓	✓	✓	-	-	-
Carbon dioxide	Technically pure, anhydrous	✓	✓	✓	-	-	-	✓	✓	✓	✓	✓	-	✓	✓	✓	✓	✓	-	-	-
Carbon tetrachloride	Technically pure	✗	-	-	✗	-	-	✗	-	-	✗	-	-	✗	-	-	✓	-	-	-	-
Carbonic acid		✓	✓	✓	-	-	-	✓	✓	✓	✓	✓	-	✓	✓	✓	✓	✓	-	-	-
Caro's acid		✓	-	-	-	-	-	-	-	-	-	-	-	-	-	-	✓	-	-	-	-
Caustic potash solution (potassium hydroxide)	50% Aqueous	✓	✓	○	-	-	-	✓	✓	✓	✓	○	-	✓	✓	✓	✗	-	-	-	-
caustic soda solution	50% Aqueous	✓	✓	✓	-	-	-	✓	✓	✓	✓	○	-	✓	✓	✓	✗	-	-	-	-
Chloric acid	10% Aqueous	✓	✓	○	✗	-	-	✓	✓	-	✗	-	-	✓	✓	✓	✓	✓	-	-	-
Chloric acid	20% Aqueous	✓	✓	○	✗	-	-	○	-	-	✗	-	-	○	○	-	✓	✓	-	-	-
Chlorine	Moist, 97% gaseous	✗	-	-	✗	-	-	✗	-	-	✗	-	-	✗	-	-	✓	-	-	-	-

KEY: – NO DATA ✗ NOT RECOMMENDED ○ CONDITIONALLY RESISTANT ✓ RESISTANT

The information in these tables has been supplied by other reputable sources and is to be used ONLY as a guide in selecting equipment for appropriate chemical compatibility. Before permanent installation, test the equipment with the chemicals and under the specific conditions of your application. Ratings of chemical behaviour listed in this chart apply to a 48-hr exposure period, we have no knowledge of possible effects beyond this period. We do not warrant (neither express or implied) that the information in this chart is accurate or complete or that any material is suitable for any purpose.

Chemical resistance – table 8.05

MecFlow Fusion is made from PP-RCT, please follow the column labeled Polypropylene.

CHEMICAL	CONCENTRATION	MATERIAL°C																			
		PVCu			ABS			PE			POLYPROPYLENE			EPDM			FPM				
		20	40	60	20	40	60	20	40	60	20	60	100	20	40	60	20	60	100	120	
Chlorine	Liquid, technically pure, as double pipe system	✗	-	-	✗	-	-	✗	-	-	✗	-	-	✗	-	-	○	-	-	-	-
Chlorine	Anhydrous, technically pure, as double pipe system	✗	-	-	✗	-	-	○	○	-	✗	-	-	○	-	-	✓	-	-	-	-
Chlorine water	Saturated	✓	✓	○	○	-	-	○	○	-	○	-	-	○	-	-	✓	-	-	-	-
Chloroacetic acid, mono	50% Aqueous	✓	✓	-	✗	-	-	✓	✓	○	✓	○	-	○	-	-	✗	-	-	-	-
Chloroacetic acid, mono	Technically pure	✓	✓	○	✗	-	-	✓	✓	○	✓	○	-	○	-	-	✗	-	-	-	-
Chlorobenzene	Technically pure	✗	-	-	✗	-	-	○	-	-	○	-	-	✗	-	-	✗	-	-	-	-
Chloroethanol	Technically pure	✗	-	-	✗	-	-	✓	✓	✓	✓	✓	-	○	-	-	✗	-	-	-	-
Chlorosulphonic acid	Technically pure	○	-	-	✗	-	-	✗	-	-	✗	-	-	✗	-	-	✗	-	-	-	-
Chromic acid	Aqueous, all	○	○	-	✗	-	-	○	-	-	○	-	-	-	-	-	✓	○	-	-	-
Chromic acid + water + sulphuric acid	50g 15g 35g	✓	✓	○	✗	-	-	✗	-	-	✗	-	-	○	○	-	✓	-	-	-	-
Chromium (II) - salts, aqueous, inorganic	<Saturated acid	✓	✓	✓	-	-	-	-	-	-	-	-	-	-	-	-	-	-	-	-	-
Compressed air, containing oil		✗	-	-	✗	-	-	✓	✓	-	○	-	-	✗	-	-	✓	-	-	-	-
Copper salts, aqueous inorganic	<Saturated acid	✓	✓	○	✓	✓	✓	✓	✓	✓	✓	✓	-	✓	✓	-	✓	✓	-	✓	✓
Cresol	Cold saturated aqueous	○	-	-	✗	-	-	✓	✓	○	✓	-	-	○	-	-	✓	-	-	-	-
Crotonic aldehyde	Technically pure	✗	-	-	✗	-	-	✓	-	-	✓	-	-	✓	-	-	✓	-	-	-	-
Cyclohexane	Technically pure	✗	-	-	✗	-	-	✓	✓	✓	✓	-	-	✗	-	-	✓	-	-	-	-
Cyclohexanol	Technically pure	✓	✓	✓	✗	-	-	✓	✓	✓	✓	○	-	✗	-	-	✓	-	-	-	-
Cyclohexanone	Technically pure	✗	-	-	✗	-	-	✓	○	○	✓	○	-	○	-	-	✗	-	-	-	-
Dextrine	Usual commercial	✓	✓	✓	✓	✓	✓	✓	✓	✓	✓	✓	-	✓	✓	✓	✓	✓	-	-	-
Disobutyl ketone	Technically pure	✗	-	-	✗	-	-	✓	○	-	✓	-	-	○	○	-	✗	-	-	-	-
Dibromobenzene	<Saturated acid	✗	-	-	✗	-	-	○	-	-	○	-	-	○	-	-	✓	-	-	-	-
Dibutyl ether	Technically pure	✗	-	-	✗	-	-	○	-	-	○	-	-	✗	-	-	✓	-	-	-	-
Dibutyl phthalate	Technically pure	✗	-	-	✗	-	-	✓	○	○	✓	○	-	○	-	-	○	-	-	-	-
Dichloroacetic acid	50% Aqueous	✓	✓	○	✗	-	-	✓	✓	○	✓	○	-	✓	✓	✓	○	✗	-	-	-
Dichloroacetic acid	Technically pure	✓	✓	○	✗	-	-	✓	✓	○	✓	○	-	✓	✓	✓	○	-	-	-	-
Dichloroacetic acid methyl ester	Technically pure	✗	-	-	✗	-	-	✓	✓	✓	✓	✓	-	✓	✓	○	✗	-	-	-	-
Dichlorobenzene	Technically pure	✗	-	-	✗	-	-	○	-	-	○	-	-	○	-	-	✓	-	-	-	-
Dichloroethylene	Technically pure	✗	-	-	✗	-	-	✗	-	-	✗	-	-	✗	-	-	○	-	-	-	-
Diesel oil		✓	✓	-	✗	-	-	✓	-	-	○	-	-	✗	-	-	✓	-	-	-	-

KEY: – NO DATA ✗ NOT RECOMMENDED ○ CONDITIONALLY RESISTANT ✓ RESISTANT

The information in these tables has been supplied by other reputable sources and is to be used ONLY as a guide in selecting equipment for appropriate chemical compatibility. Before permanent installation, test the equipment with the chemicals and under the specific conditions of your application. Ratings of chemical behaviour listed in this chart apply to a 48-hr exposure period, we have no knowledge of possible effects beyond this period. We do not warrant (neither express or implied) that the information in this chart is accurate or complete or that any material is suitable for any purpose.

Chemical resistance – table 8.06

MecFlow Fusion is made from PP-RCT, please follow the column labeled Polypropylene.

CHEMICAL	CONCENTRATION	MATERIAL°C																			
		PVCu			ABS			PE			POLYPROPYLENE			EPDM			FPM				
		20	40	60	20	40	60	20	40	60	20	60	100	20	40	60	20	60	100	120	
Diethyl ether		x	-	-	x	-	-	x	-	-	x	-	-	x	-	-	x	-	-	-	-
Diethylamine	Technically pure	-	-	-	x	-	-	✓	-	-	✓	-	-	○	-	-	x	-	-	-	-
Dimethyl formamide	Technically pure	x	-	-	x	-	-	✓	✓	○	✓	✓	-	○	-	-	x	-	-	-	-
Dimethylamine	Technically pure	x	-	-	x	-	-	✓	-	-	x	-	-	○	-	-	x	-	-	-	-
Dioxane	Technically pure	x	-	-	x	-	-	✓	✓	✓	○	○	-	○	-	-	x	-	-	-	-
Ethanolamine	Technically pure	x	-	-	x	-	-	✓	-	-	✓	-	-	✓	-	-	○	-	-	-	-
Ethyl alcohol (Ethnause)	Technically pure 96%	✓	✓	○	x	-	-	✓	✓	✓	✓	✓	-	✓	✓	✓	✓	○	-	-	-
Ethyl benzene	Technically pure	x	-	-	x	-	-	○	-	-	○	-	-	x	-	-	✓	-	-	-	-
Ethyl chloride (G)	Technically pure	x	-	-	x	-	-	○	-	-	○	-	-	x	-	-	○	-	-	-	-
Ethyl ether	Technically pure	x	-	-	x	-	-	✓	-	-	○	-	-	x	-	-	x	-	-	-	-
Ethylene diamine	Technically pure	○	-	-	x	-	-	✓	✓	✓	✓	✓	-	✓	-	-	○	x	-	-	-
Ethylene glycol	<50%	✓	✓	✓	○	○	-	✓	✓	✓	✓	✓	-	✓	✓	✓	✓	✓	-	-	-
Ethylene glycol	Technically pure	✓	✓	✓	x	-	-	✓	✓	✓	✓	✓	-	✓	✓	✓	✓	✓	-	-	-
Ethylenediamine -tetraacetic acid (EDTA)		-	-	-	-	-	-	✓	-	-	✓	-	-	✓	-	-	-	-	-	-	-
Fluorine	Technically pure	x	-	-	x	-	-	x	-	-	x	-	-	x	-	-	x	-	-	-	-
Fluorosilic acid	32% Aqueous	✓	✓	✓	-	-	-	✓	✓	✓	✓	✓	-	✓	-	-	○	-	-	-	-
Formaldehyde	40% Aqueous	✓	✓	-	-	-	-	✓	✓	✓	✓	-	-	✓	✓	✓	✓	✓	-	-	-
Formamide	Technically pure	x	-	-	x	-	-	✓	✓	✓	✓	✓	-	✓	-	-	○	-	-	-	-
Formic acid	≥25%	✓	✓	✓	-	-	-	✓	✓	✓	✓	✓	-	✓	✓	✓	-	-	-	-	-
Formic acid	Up to 50% aqueous	✓	✓	○	○	-	-	✓	✓	✓	✓	○	-	✓	✓	○	✓	○	-	-	-
Formic acid	Technically pure	✓	○	x	x	-	-	✓	✓	✓	✓	x	-	✓	✓	○	✓	-	-	-	-
Frigen 12 (freon 12)	Technically pure	✓	-	-	x	-	-	x	-	-	x	-	-	○	-	-	○	-	-	-	-
Fuel oil		✓	✓	-	x	-	-	✓	-	-	○	-	-	x	-	-	✓	-	-	-	-
Furfuryl alcohol	Technically pure	x	-	-	x	-	-	✓	✓	✓	✓	○	-	○	-	-	x	-	-	-	-
Gelatin	Aqueous, all	✓	✓	-	✓	✓	✓	✓	✓	✓	✓	✓	-	✓	✓	-	✓	-	-	-	-
Glucose	Aqueous, all	✓	✓	○	-	-	-	✓	✓	✓	✓	✓	-	✓	✓	✓	✓	✓	-	-	-
Glycerol	Technically pure	✓	✓	✓	-	-	-	✓	✓	✓	✓	✓	-	✓	○	○	✓	○	-	-	-
Glycin	10% Aqueous	✓	✓	-	✓	✓	-	✓	✓	-	✓	-	-	-	-	-	✓	-	-	-	-
Glycolic acid	37% Aqueous	✓	-	-	-	-	-	✓	✓	✓	✓	-	-	-	-	-	✓	-	-	-	-
Heptane	Technically pure	✓	✓	-	x	-	-	✓	✓	-	○	-	-	x	-	-	✓	-	-	-	-

KEY: – NO DATA x NOT RECOMMENDED ○ CONDITIONALLY RESISTANT ✓ RESISTANT

The information in these tables has been supplied by other reputable sources and is to be used ONLY as a guide in selecting equipment for appropriate chemical compatibility. Before permanent installation, test the equipment with the chemicals and under the specific conditions of your application. Ratings of chemical behaviour listed in this chart apply to a 48-hr exposure period, we have no knowledge of possible effects beyond this period. We do not warrant (neither express or implied) that the information in this chart is accurate or complete or that any material is suitable for any purpose.

Chemical resistance – table 8.07

MecFlow Fusion is made from PP-RCT, please follow the column labeled Polypropylene.

CHEMICAL	CONCENTRATION	MATERIAL°C																			
		PVCu			ABS			PE			POLYPROPYLENE			EPDM			FPM				
		20	40	60	20	40	60	20	40	60	20	60	100	20	40	60	20	60	100	120	
Hexane	Technically pure	✓	✓	-	x	-	-	✓	✓	-	○	-	-	x	-	-	✓	-	-	-	-
Hydrazine hydrate	Aqueous	✓	-	-	x	-	-	✓	✓	✓	✓	✓	-	✓	-	-	○	-	-	-	-
Hydrochloric acid	Up to 30% aqueous	✓	✓	○	-	-	-	✓	✓	✓	✓	○	-	✓	✓	○	✓	○	-	-	-
Hydrochloric acid	38% Aqueous	✓	✓	○	x	-	-	✓	✓	-	○	-	-	✓	○	-	✓	-	-	-	-
Hydrocyanic acid	Technically pure	✓	✓	○	x	-	-	✓	✓	✓	✓	✓	-	✓	○	-	✓	-	-	-	-
Hydrofluoric acid	40%	✓	○	○	x	-	-	✓	✓	○	✓	✓	-	x	-	-	✓	○	-	-	-
Hydrogen	Technically pure	✓	✓	✓	✓	✓	✓	✓	✓	✓	✓	✓	x	✓	✓	-	✓	✓	✓	-	-
Hydrogen chloride	Technically pure gaseous	✓	✓	○	x	-	-	✓	✓	✓	✓	✓	-	✓	✓	✓	✓	✓	-	-	-
Hydrogen peroxide	30% Aqueous	✓	-	-	x	-	-	✓	-	-	✓	-	-	○	-	-	✓	-	-	-	-
Hydrogen peroxide	90% Aqueous	✓	-	-	x	-	-	○	-	-	-	-	-	x	-	-	○	-	-	-	-
Hydrogen sulphide	Saturated aqueous	✓	✓	○	-	-	-	✓	✓	✓	✓	✓	-	✓	x	-	✓	✓	-	-	-
Hydrogen sulphide	Technically pure	✓	✓	✓	-	-	-	✓	✓	○	✓	✓	-	✓	x	-	✓	○	-	-	-
Hydrquinone	30%	✓	✓	-	-	-	-	✓	✓	✓	✓	✓	-	✓	-	-	-	-	-	-	-
Iodine-potassium iodide solution (Lugol's solution)		✓	-	-	x	-	-	✓	-	-	✓	-	-	✓	-	-	✓	-	-	-	-
Iron salts, aqueous inorganic	≥Saturated acid	✓	✓	✓	✓	-	-	✓	✓	✓	✓	✓	-	✓	✓	✓	✓	✓	✓	-	-
Isocetane	Technically pure	✓	-	-	x	-	-	✓	-	-	✓	-	-	-	-	-	✓	-	-	-	-
Isopropyl alcohol (ESC)	Technically pure	✓	✓	○	-	-	-	✓	✓	○	✓	○	-	✓	✓	-	✓	-	-	-	-
Isopropyl ether	Technically pure	x	-	-	x	-	-	○	-	-	○	-	-	○	-	-	x	-	-	-	-
Lactic acid	10% Aqueous	✓	○	x	✓	○	x	✓	✓	✓	✓	✓	-	✓	✓	○	✓	○	-	-	-
Lead acetate	Aqueous saturated	✓	✓	✓	✓	✓	✓	✓	✓	✓	✓	✓	-	✓	✓	✓	✓	✓	-	-	-
Lead salts, aqueous, inorganic	≥Saturated acid	✓	✓	✓	-	-	-	✓	✓	✓	✓	✓	-	✓	✓	✓	✓	✓	-	-	-
Linseed oil	Technically pure	✓	✓	○	-	-	-	✓	✓	✓	✓	✓	-	✓	✓	✓	✓	✓	-	-	-
Lithium salts, aqueous, inorganic	≥Saturated acid	✓	✓	✓	-	-	-	✓	✓	✓	✓	✓	-	✓	✓	✓	✓	✓	-	-	-
Magnesium salts, aqueous inorganic	≥Saturated acid	✓	✓	○	-	-	-	✓	✓	✓	✓	✓	-	✓	✓	✓	✓	✓	-	-	-
Maleic acid	Cold saturated aqueous	✓	✓	○	-	-	-	✓	✓	✓	✓	✓	-	✓	✓	✓	✓	✓	-	-	-
Mercury	Pure	✓	✓	✓	✓	-	-	✓	✓	✓	✓	✓	-	✓	✓	✓	✓	✓	-	-	-
Mercury salts	≥Saturated acid	✓	✓	○	-	-	-	✓	✓	✓	✓	✓	-	✓	✓	✓	✓	✓	-	-	-
Methane (natural gas)	Technically pure	✓	-	-	✓	-	-	✓	-	-	✓	-	-	-	-	-	✓	-	-	-	-
Methanol	All	✓	✓	○	x	-	-	✓	✓	✓	✓	✓	-	✓	✓	✓	○	○	-	-	-
Methyl acetate	Technically pure	x	-	-	x	-	-	✓	-	-	✓	-	-	✓	-	-	x	-	-	-	-

KEY: – NO DATA x NOT RECOMMENDED ○ CONDITIONALLY RESISTANT ✓ RESISTANT

The information in these tables has been supplied by other reputable sources and is to be used ONLY as a guide in selecting equipment for appropriate chemical compatibility. Before permanent installation, test the equipment with the chemicals and under the specific conditions of your application. Ratings of chemical behaviour listed in this chart apply to a 48-hr exposure period, we have no knowledge of possible effects beyond this period. We do not warrant (neither express or implied) that the information in this chart is accurate or complete or that any material is suitable for any purpose.

## Chemical resistance – table 8.08

MecFlow Fusion is made from PP-RCT, please follow the column labeled Polypropylene.

CHEMICAL	CONCENTRATION	MATERIAL°C																			
		PVCu			ABS			PE			POLYPROPYLENE				EPDM			FPM			
		20	40	60	20	40	60	20	40	60	20	60	100	20	40	60	20	60	100	120	
Methyl amine	32% Aqueous	○	-	-	×	-	-	✓	-	-	✓	-	-	✓	-	-	×	-	-	-	-
Methyl bromide	Technically pure	×	-	-	×	-	-	○	-	-	×	-	-	×	-	-	○	-	-	-	-
Methyl ethyl ketone	Technically pure	×	-	-	×	-	-	✓	-	-	✓	-	-	✓	-	-	×	-	-	-	-
Methyl isobutyl ketone		×	-	-	×	-	-	✓	-	-	✓	-	-	✓	-	-	×	-	-	-	-
Methyl methacrylate		×	-	-	×	-	-	✓	-	-	✓	-	-	✓	-	-	×	-	-	-	-
Methyl phenyl(acetophenon)		×	-	-	×	-	-	✓	-	-	✓	-	-	✓	-	-	×	-	-	-	-
Milk		✓	✓	✓	✓	✓	✓	✓	✓	✓	✓	✓	✓	-	-	-	✓	-	-	-	-
Mineral water		✓	✓	✓	✓	✓	✓	✓	✓	✓	✓	✓	✓	✓	✓	✓	✓	✓	✓	✓	✓
Mixed acids - nitric 15% - hydrofluoric 15% - sulphuric 18%	3 parts 1 part 2 parts	✓	-	-	×	-	-	○	-	-	×	-	-	×	-	-	✓	-	-	-	-
Mixed acids - sulphuric - nitric - water	10% 20% 70%	✓	✓	✓	×	-	-	✓	-	-	×	-	-	×	-	-	✓	✓	-	-	-
Mixed acids - sulphuric - nitric - water	50% 33% 17%	✓	○	-	×	-	-	×	-	-	×	-	-	×	-	-	✓	-	-	-	-
Mixed acids - sulphuric - nitric - water	50% 31% 19%	✓	-	-	×	-	-	×	-	-	×	-	-	×	-	-	✓	-	-	-	-
Mixed acids - sulphuric - phosphoric - water	30% 60% 10%	✓	✓	-	×	-	-	✓	✓	✓	✓	✓	-	✓	✓	✓	✓	✓	-	-	-
N, N-Dimethylaniline	Technically pure	×	-	-	×	-	-	✓	-	-	✓	-	-	✓	-	-	-	-	-	-	-
N, methylpyrrolidon		×	-	-	×	-	-	✓	-	-	✓	-	-	✓	-	-	○	-	-	-	-
Naphthalene	Technically pure	×	-	-	-	-	-	✓	-	-	✓	-	-	×	-	-	✓	-	-	-	-
Nickel salts, aqueous in organic	≥Saturated acid	✓	✓	○	-	-	-	✓	✓	✓	✓	✓	-	✓	✓	✓	✓	✓	-	-	-
Nitrating acid - sulphuric acid - nitric acid - water	65% 20% 15%	✓	○	-	-	-	-	×	-	-	×	-	-	×	-	-	✓	-	-	-	-
Nitric acid	6.3% Aqueous	✓	✓	✓	-	-	-	✓	✓	✓	✓	○	-	✓	○	-	✓	✓	-	-	-
Nitric acid	≥25%	✓	✓	✓	×	-	-	✓	✓	○	✓	-	-	✓	-	-	✓	-	-	-	-
Nitric acid	65% Aqueous	○	○	×	×	-	-	○	×	-	×	-	-	×	-	-	✓	×	-	-	-
Nitric acid	85%	×	-	-	×	-	-	×	-	-	×	-	-	×	-	-	✓	-	-	-	-
Nitric acid	100%	×	-	-	×	-	-	×	-	-	×	-	-	×	-	-	×	-	-	-	-

KEY: – NO DATA × NOT RECOMMENDED ○ CONDITIONALLY RESISTANT ✓ RESISTANT

The information in these tables has been supplied by other reputable sources and is to be used ONLY as a guide in selecting equipment for appropriate chemical compatibility. Before permanent installation, test the equipment with the chemicals and under the specific conditions of your application. Ratings of chemical behaviour listed in this chart apply to a 48-hr exposure period, we have no knowledge of possible effects beyond this period. We do not warrant (neither express or implied) that the information in this chart is accurate or complete or that any material is suitable for any purpose.

## Chemical resistance – table 8.09

MecFlow Fusion is made from PP-RCT, please follow the column labeled Polypropylene.

CHEMICAL	CONCENTRATION	MATERIAL°C																			
		PVCu			ABS			PE			POLYPROPYLENE				EPDM			FPM			
		20	40	60	20	40	60	20	40	60	20	60	100	20	40	60	20	60	100	120	
Nitrobenzene	Technically pure	×	-	-	×	-	-	✓	-	-	✓	-	-	○	-	-	✓	-	-	-	-
Nitrotoluene (o-, m-, p-)	Technically pure	×	-	-	×	-	-	✓	○	-	○	-	-	×	-	-	○	-	-	-	-
Nitrous acid		✓	✓	-	×	-	-	✓	-	-	×	-	-	✓	-	-	✓	-	-	-	-
Nitrous gases (nitric oxide)	Diluted, moist, anhydrous	✓	-	-	×	-	-	○	-	-	○	-	-	○	-	-	✓	-	-	-	-
Oleic	Technically pure	✓	✓	✓	×	-	-	✓	✓	○	✓	○	-	×	-	-	✓	×	-	-	-
Oleum	10% SO3	×	-	-	×	-	-	×	-	-	×	-	-	×	-	-	×	-	-	-	-
Olive oil		✓	✓	✓	×	-	-	✓	✓	○	✓	✓	-	×	-	-	✓	✓	-	-	-
Oxygen	Technically pure	✓	✓	✓	-	-	-	✓	✓	○	✓	○	-	✓	✓	✓	✓	✓	✓	✓	✓
Ozone	Up to 2%, in air	✓	-	-	×	-	-	○	-	-	○	-	-	○	-	-	✓	-	-	-	-
Ozone	Cold saturated, aqueous	✓	-	-	×	-	-	○	-	-	○	-	-	×	-	-	✓	-	-	-	-
Palm oil, palm nut oil		✓	-	-	-	-	-	✓	-	-	✓	-	-	×	-	-	✓	-	-	-	-
Paraffin emulsions	Usual commercial, aqueous	✓	-	-	-	-	-	✓	-	-	✓	-	-	×	-	-	✓	-	-	-	-
Paraffin oil		✓	-	-	○	-	-	✓	-	-	✓	-	-	×	-	-	✓	-	-	-	-
Perchloric acid	10% Aqueous	✓	-	-	-	-	-	✓	-	-	✓	-	-	✓	-	-	✓	-	-	-	-
Perchloric acid	70% Aqueous	✓	-	-	×	-	-	-	-	-	×	-	-	×	-	-	✓	-	-	-	-
Perchloroethylene (tetrachlorethylene)	Technically pure	×	-	-	-	-	-	○	-	-	○	-	-	×	-	-	✓	✓	-	-	-
Phenol	Up to 10% aqueous	✓	○	-	×	-	-	✓	✓	○	✓	✓	-	✓	✓	○	✓	✓	-	-	-
Phenol	Up to 90% aqueous	○	-	-	×	-	-	✓	✓	○	✓	✓	-	×	-	-	✓	×	-	-	-
Phosgene	Gaseous technically pure	✓	○	○	×	-	-	○	-	-	○	-	-	✓	-	-	✓	○	-	-	-
Phosgene	Liquid, technically pure	×	-	-	×	-	-	×	-	-	×	-	-	×	-	-	✓	-	-	-	-
Phosphoric acid	85% Aqueous	✓	✓	✓	-	-	-	✓	✓	✓	✓	✓	-	✓	✓	○	✓	✓	○	-	-
Phosphoric acid	Up to 95%	✓	✓	-	×	-	-	✓	✓	-	✓	✓	-	○	-	-	✓	○	-	-	-
Phosphorous chlorides - trichloride - pentachloride - oxichloride	Technically pure	×	-	-	×	-	-	×	-	-	×	-	-	-	-	-	×	-	-	-	-
Photographic developer	Usual commercial	✓	✓	○	✓	✓	○	✓	✓	○	✓	-	-	✓	✓	-	✓	-	-	-	-
Photographic emulsions		✓	✓	-	✓	✓	-	✓	✓	-	✓	-	-	✓	✓	-	✓	-	-	-	-
Photographic fixer	Usual commercial	✓	✓	○	✓	✓	○	✓	✓	-	✓	-	-	✓	✓	-	✓	-	-	-	-
Phthalic acid	Saturated, aqueous	✓	○	×	×	-	-	✓	✓	✓	✓	✓	-	✓	○	-	×	-	-	-	-
Potassium hydroxide	50%	✓	✓	✓	-	-	-	✓	✓	✓	✓	○	-	✓	✓	✓	×	-	-	-	-

KEY: – NO DATA × NOT RECOMMENDED ○ CONDITIONALLY RESISTANT ✓ RESISTANT

The information in these tables has been supplied by other reputable sources and is to be used ONLY as a guide in selecting equipment for appropriate chemical compatibility. Before permanent installation, test the equipment with the chemicals and under the specific conditions of your application. Ratings of chemical behaviour listed in this chart apply to a 48-hr exposure period, we have no knowledge of possible effects beyond this period. We do not warrant (neither express or implied) that the information in this chart is accurate or complete or that any material is suitable for any purpose.

Chemical resistance – table 8.10

MecFlow Fusion is made from PP-RCT, please follow the column labeled Polypropylene.

CHEMICAL	CONCENTRATION	MATERIAL°C																				
		PVCu			ABS			PE			POLYPROPYLENE			EPDM			FPM					
		20	40	60	20	40	60	20	40	60	20	60	100	20	40	60	20	60	100	120		
Potassium aluminium salts, (alum), aqueous, inorganic	≤Saturated acid	✓	✓	✓	-	-	-	✓	✓	✓	✓	✓	-	✓	✓	✓	-	-	-	-	-	-
Potassium persulphate (potassium peroxodisulfate)	All, aqueous	✓	✓	○	-	-	-	✓	✓	✓	✓	✓	-	✓	✓	-	✓	✓	-	-	-	-
Potassium hypochlorite		✓	○	-	-	-	-	○	-	-	○	-	-	✓	-	-	○	-	-	-	-	-
Propane	Technically pure, gaseous	✓	✓	-	-	-	-	○	-	-	✓	-	-	-	-	-	✓	-	-	-	-	-
Propane	Technically pure, liquid	✓	✓	-	-	-	-	✓	-	-	✓	-	-	-	-	-	✓	-	-	-	-	-
Propanol, n- and iso-	Technically pure	✓	○	○	-	-	-	✓	✓	○	✓	○	-	✓	✓	○	✓	-	-	-	-	-
Propionic acid	50% Aqueous	✓	✓	○	×	-	-	✓	✓	✓	✓	✓	-	✓	✓	-	○	-	-	-	-	-
Propionic acid	Technically pure	✓	○	-	×	-	-	✓	○	○	✓	○	-	✓	○	-	✓	✓	-	-	-	-
Propylene glycol	<50%	✓	✓	✓	-	-	-	✓	✓	✓	✓	✓	-	✓	✓	-	✓	○	-	-	-	-
Propylene glycol	Technically pure	✓	✓	✓	✓	-	-	✓	✓	✓	✓	✓	-	✓	✓	✓	✓	✓	-	-	-	-
Pyridine	Technically pure	×	-	-	×	-	-	✓	○	○	○	○	-	○	-	-	×	-	-	-	-	-
Salicylic acid	Saturated	✓	✓	✓	-	-	-	✓	✓	✓	✓	✓	-	✓	✓	✓	✓	-	-	-	-	-
Sea water		✓	✓	○	✓	✓	✓	✓	✓	✓	✓	✓	✓	✓	✓	✓	✓	✓	✓	-	-	-
Silicic acid		✓	✓	✓	-	-	-	✓	✓	✓	✓	✓	-	✓	✓	✓	✓	-	-	-	-	-
Silicone oil		✓	○	×	✓	-	-	✓	✓	✓	✓	✓	-	✓	✓	✓	✓	✓	-	-	-	-
Silver salts, aqueous, inorganic	≤Saturated acid	✓	✓	✓	✓	-	-	✓	✓	✓	✓	✓	-	✓	✓	✓	✓	✓	-	-	-	-
Sodium chlorite	Diluted, aqueous	✓	-	-	-	-	-	○	-	-	○	-	-	○	-	-	✓	-	-	-	-	-
Sodium hypochlorite	12.5% Active chlorine, aqueous	✓	✓	-	×	-	-	○	○	-	○	-	-	✓	✓	-	○	-	-	-	-	-
Sodium persulphate	Cold saturated, aqueous	✓	✓	○	-	-	-	✓	✓	✓	✓	✓	-	✓	✓	-	✓	✓	-	-	-	-
Sodium salts, aqueous, inorganic	≤Saturated acid	✓	✓	✓	-	-	-	✓	✓	✓	✓	✓	-	✓	✓	✓	✓	✓	-	-	-	-
Stannous chloride	Cold saturated, aqueous	✓	○	○	✓	✓	-	✓	✓	✓	✓	✓	-	✓	○	×	✓	✓	-	-	-	-
Starch solution	Aqueous all	✓	✓	✓	✓	✓	-	✓	✓	✓	✓	✓	-	✓	✓	✓	✓	✓	-	-	-	-
Styrene		×	-	-	×	-	-	-	-	-	-	-	-	-	-	-	✓	-	-	-	-	-
Succinic acid	Aqueous ,all	✓	✓	✓	✓	-	-	✓	✓	✓	✓	✓	-	✓	✓	✓	✓	✓	-	-	-	-
Sulfuryl chloride	Technically pure	×	-	-	×	-	-	×	-	-	×	-	-	-	-	-	✓	-	-	-	-	-
Sulphur dioxide	Technically pure, liquid	×	-	-	×	-	-	×	-	-	×	-	-	×	-	-	○	-	-	-	-	-
Sulphur dioxide	All, moist	✓	✓	○	×	-	-	✓	✓	✓	✓	✓	-	✓	○	×	✓	×	-	-	-	-
Sulphuric acid	Saturated aqueous	✓	✓	○	-	-	-	✓	✓	✓	✓	✓	-	✓	×	-	✓	○	-	-	-	-
Sulphuric acid	Up to 80% aqueous	✓	✓	✓	×	-	-	✓	✓	○	✓	○	-	○	○	×	✓	○	-	-	-	-
Sulphuric acid	Up to 96% aqueous	✓	✓	○	×	-	-	×	-	-	×	-	-	×	-	-	✓	✓	-	-	-	-

KEY: – NO DATA × NOT RECOMMENDED ○ CONDITIONALLY RESISTANT ✓ RESISTANT

The information in these tables has been supplied by other reputable sources and is to be used ONLY as a guide in selecting equipment for appropriate chemical compatibility. Before permanent installation, test the equipment with the chemicals and under the specific conditions of your application. Ratings of chemical behaviour listed in this chart apply to a 48-hr exposure period, we have no knowledge of possible effects beyond this period. We do not warrant (neither express or implied) that the information in this chart is accurate or complete or that any material is suitable for any purpose.

Chemical resistance – table 8.11

MecFlow Fusion is made from PP-RCT, please follow the column labeled Polypropylene.

CHEMICAL	CONCENTRATION	MATERIAL°C																					
		PVCu			ABS			PE			POLYPROPYLENE			EPDM			FPM						
		20	40	60	20	40	60	20	40	60	20	60	100	20	40	60	20	60	100	120			
Sulphuric acid	98%	✓	○	-	×	-	-	×	-	-	×	-	-	×	-	-	×	-	-	○	-	-	-
Tannic acid	Aqueous all	✓	-	-	-	-	-	✓	✓	✓	✓	✓	-	-	-	-	✓	-	-	-	-	-	-
Tetrachlorethylene (perchloroethylene)		×	-	-	×	-	-	×	-	-	×	-	-	×	-	-	×	-	-	✓	-	-	-
Tetrachloroethane	Technically pure	×	-	-	×	-	-	○	-	-	○	-	-	×	-	-	○	-	-	○	-	-	-
Tetraethylene lead	Technically pure	✓	-	-	×	-	-	✓	-	-	✓	-	-	○	-	-	○	-	-	✓	-	-	-
Tetrahydrofurane	Technically pure	×	-	-	×	-	-	○	-	-	○	-	-	○	-	-	○	-	-	×	-	-	-
Tin salts, aqueous, inorganic	≤Saturated acid	✓	✓	✓	-	-	-	✓	✓	✓	✓	✓	-	✓	✓	✓	✓	✓	✓	✓	-	-	-
Toluene	Technically pure	×	-	-	×	-	-	○	-	-	○	-	-	×	-	-	✓	-	-	-	-	-	-
Trichloromethane	100%	-	-	-	-	-	-	-	-	-	-	-	-	-	-	-	-	-	-	✓	-	-	-
Trichloroacetic acid	50% Aqueous	✓	○	-	×	-	-	✓	✓	✓	✓	✓	-	✓	○	-	○	-	-	×	-	-	-
Trichloroacetic acid	Technically pure	○	-	-	×	-	-	✓	○	×	✓	○	-	○	-	-	○	-	-	×	-	-	-
Trichloroethane	Technically pure	×	-	-	×	-	-	○	-	-	○	-	-	×	-	-	✓	-	-	-	-	-	-
Trichloroethylene	Technically pure	×	-	-	×	-	-	×	-	-	○	-	-	×	-	-	✓	-	-	-	-	-	-
Triethylamine	Technically pure	×	-	-	×	-	-	✓	-	-	✓	-	-	×	-	-	×	-	-	×	-	-	-
Trifluoroacetic acid	Up to 50%	×	-	-	×	-	-	✓	-	-	✓	-	-	○	-	-	○	-	-	×	-	-	-
Turpentine oil	Technically pure	✓	○	-	×	-	-	○	○	-	×	-	-	×	-	-	×	-	-	✓	✓	-	-
Urea	Up to 30% aqueous	✓	✓	○	✓	✓	-	✓	✓	✓	✓	✓	-	✓	✓	✓	✓	✓	✓	✓	-	-	-
Urine		✓	✓	○	-	-	-	✓	✓	✓	✓	✓	-	✓	✓	✓	✓	✓	✓	✓	-	-	-
Vinyl acetate	Technically pure	×	-	-	×	-	-	✓	✓	-	✓	○	-	✓	-	-	✓	-	-	×	-	-	-
Vinyl chloride	Technically pure	×	-	-	×	-	-	×	-	-	×	-	-	×	-	-	×	-	-	✓	-	-	-
Waste gases, containing alkaline		✓	✓	✓	-	-	-	✓	✓	✓	✓	✓	-	✓	✓	✓	✓	✓	✓	✓	✓	×	-
Waste gases, containing hydrochloric acid	All	✓	✓	✓	-	-	-	✓	✓	✓	✓	✓	-	✓	✓	✓	✓	✓	✓	✓	✓	✓	-
Waste gases, containing hydrogen fluoride	Traces	✓	✓	✓	-	-	-	✓	✓	✓	✓	✓	-	✓	✓	-	○	○	○	✓	✓	-	-
Waste gases, containing nitrous gases	Traces	✓	✓	✓	-	-	-	✓	○	○	○	○	-	✓	○	○	✓	○	○	✓	✓	○	-
Waste gases, containing sulphur dioxide	Traces	○	✓	-	-	-	-	✓	✓	-	✓	-	-	✓	✓	✓	✓	✓	✓	✓	✓	✓	-
Water, drinking, chlorinated	≤0.1ppm Chlorine	✓	✓	✓	✓	✓	✓	✓	✓	✓	✓	✓	-	✓	✓	✓	✓	✓	○	✓	✓	✓	-
Water - distilled - deionised		✓	✓	✓	✓	✓	✓	✓	✓	✓	✓	✓	-	✓	✓	✓	✓	✓	○	✓	✓	✓	✓
Xylene	Technically pure	×	-	-	×	-	-	×	-	-	×	-	-	×	-	-	×	-	-	✓	×	-	-
Zinc salts, aqueous, inorganic	≤Saturated acid	✓	✓	✓	✓	-	-	✓	✓	✓	✓	✓	-	✓	✓	✓	✓	✓	✓	✓	✓	-	-

KEY: – NO DATA × NOT RECOMMENDED ○ CONDITIONALLY RESISTANT ✓ RESISTANT

The information in these tables has been supplied by other reputable sources and is to be used ONLY as a guide in selecting equipment for appropriate chemical compatibility. Before permanent installation, test the equipment with the chemicals and under the specific conditions of your application. Ratings of chemical behaviour listed in this chart apply to a 48-hr exposure period, we have no knowledge of possible effects beyond this period. We do not warrant (neither express or implied) that the information in this chart is accurate or complete or that any material is suitable for any purpose.

# 9. System commissioning & maintenance

The purpose of system commissioning is to test that the system as installed is leak-free, clear of impurities and – where required – is disinfected before being placed into service. In the UK there are several guidance documents that detail how to test and flush the system, which include (but aren't limited to):

- BS EN 806-4 - Specifications for installations inside buildings conveying water for human consumption.
- BS 8558 - Guide to the design, installation, testing and maintenance of services supplying water for domestic use within buildings and their curtilages. Complementary guidance to BS EN 806.
- WRAS Water Regulations Guide.
- The Control of Legionella in Water Systems - Approved Code of Practice L8.
- Guidance on which systems require disinfection prior to commissioning is also detailed in the aforementioned documents.

## HYDROSTATIC PRESSURE TESTING

The MecFlow Fusion system should be tested as a plastic system as described in the above guidance documents. There are two test methods, Test A and Test B (graphs 9.01 & 9.02), prescribed for the testing of plastic systems. Either of these methods are suitable for MecFlow Fusion.

Although the MecFlow Fusion system can comfortably be tested at 1.5 times its nominal pressure rating, care should be taken to check that all components, supplied by others, installed in the MecFlow Fusion system are able to withstand the applied test pressure. Once the hydrostatic pressure test is completed, the result should be recorded and documented as per the client's requirement.

## Water tightness procedure - Test A

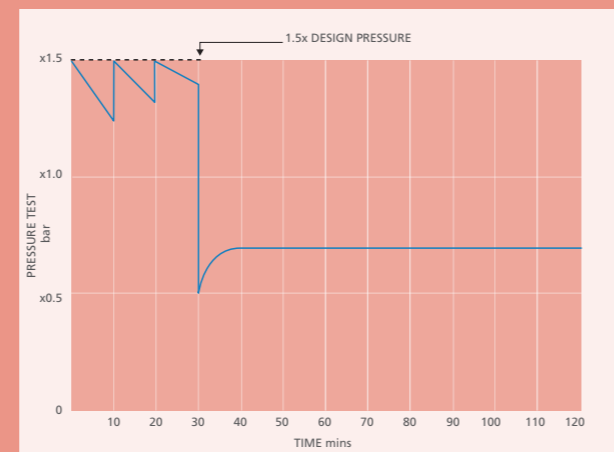

Graph 9.01

## Water tightness procedure - Test B

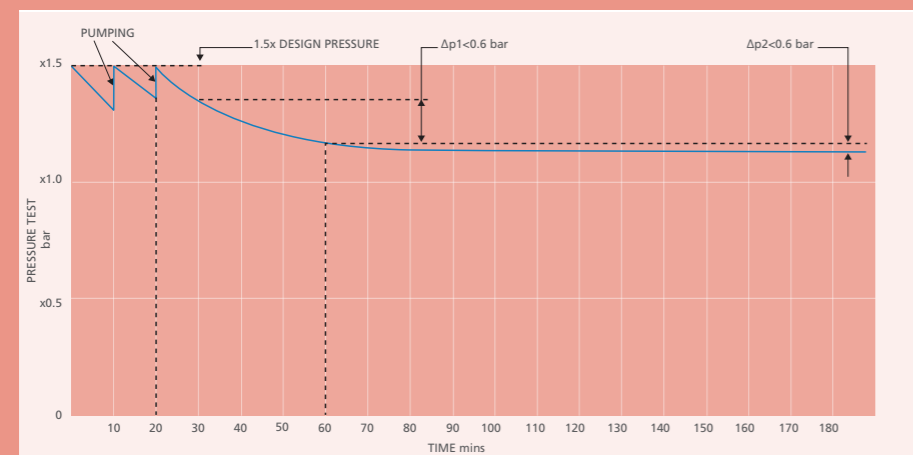

Graph 9.02

## TESTING WITH AIR

It is not recommended to site test the MecFlow Fusion system using compressed air.

# System commissioning & maintenance

## SYSTEM REPAIR

If a leak is discovered in the MecFlow Fusion system during testing, a repair can be made by 'cutting in' using MecFlow Fusion couplings as slip couplings.

### Cutting in a new section of MecFlow Fusion using electrofusion couplings

1. Drain the system completely before cutting out the repair section.
2. Measure and mark the section(s) to be cut out.
3. Cut out the section for repair. Make sure the cuts are square.

4. Ensure the cut pipe ends are dry. Mark the EF coupling insertion depth.
5. De-oxidise the pipe ends ready for welding.
6. Prepare the repair piece and de-oxidise the pipe ends.
7. Remove the internal stop of the electrofusion couplers.
8. Offer the repair piece up to the job and slip the couplings onto the system.
9. Line the couplings up to the insertion depth marks on both sides.

10. Ensure there is no external stress on the system and/or couplings.
11. Go through the welding process as described in Joining Methods, Section 6.
12. The system can be re-tested once the EF couplings have completed their cooling time.

Diagram 9.03

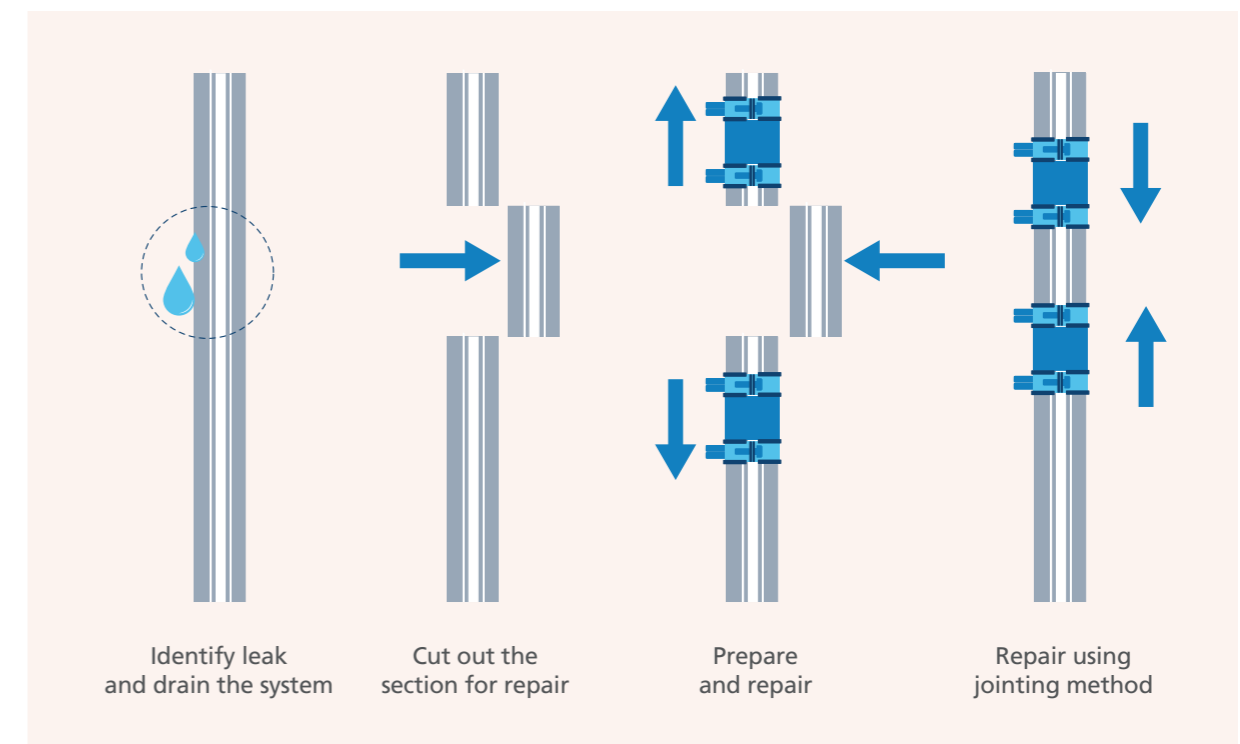

## System commissioning & maintenance

### SYSTEM FLUSHING

Once the hydrostatic test has been successfully completed the system should be flushed with drinking water immediately before commissioning. Flushing should be carried out in accordance with the aforementioned guidance documents. If the system is not placed in service after testing and flushing, it should be flushed according to procedures at regular intervals.

### CHEMICAL DISINFECTION

Where a MecFlow Fusion system needs to be disinfected before being brought into service, the methods described in the previously mentioned guidance documents must be strictly adhered to.

Care must be taken to select the correct disinfectant, ensure that the dilution is controlled, ensure the level of disinfectant over a given contact period is observed, that samples are taken at the correct points to assess the efficiency of the disinfection, and finally that the system is thoroughly flushed through after the disinfection to remove the disinfectant before the system is put into service.

### THERMAL DISINFECTION

MecFlow Fusion can withstand thermal disinfection process  $\leq 70^{\circ}\text{C}$ .

### SHOCK CHEMICAL DISINFECTION

Although the MecFlow Fusion system does not promote bacterial growth, it is possible that it may be installed in a system that, under certain circumstances, could require disinfection during its service life – either as part of a maintenance regime or because the level of bacterial growth in the total system presents a hazard.

In this instance, the total system may require shock disinfection. Documents such as 'The Control of Legionella in Water Systems – Approved Code of Practice L8' provide guidance on methods of shock disinfection, and these must be rigidly adhered to. If there is any doubt about the method, chemical, temperature or contact period prescribed in the above, or any other guidance document, then please contact the Polypipe Advantage team on 01622 392215 for further technical advice.

### CHLORINE DIOXIDE

The use of chlorine dioxide as a disinfectant is permitted however the level of constant dosing must be strictly controlled and shall not exceed 0.5mg/l. Guidance as to the use of this chemical as a disinfectant is provided in BS EN 806 and the addendum BS 8558:2015. Further guidance is provided in ACoP L8.



# 10. Approvals

## Quality Management System

The MecFlow Fusion range is manufactured under a strict Quality Management System (QMS). The Quality Management System is periodically third party audited and certified to ISO 9001 Quality Management.

The system requires demonstrated compliance to:

- Organisational competence, training and documentation.
- QA measurement and test equipment – periodic calibration and documentation.
- Inspection and measurement of input raw material and documentation.
- Process control documentation and recording of process conditions.
- Inspection and measurement of finished product and documentation.
- Treatment, storage and handling of finished product and documentation.
- Product marking and traceability.
- Treatment of non-conforming material/product, corrective action and documentation.
- New product design and change of product design process, recording and documentation.

Contact the Polypipe Advantage team on 01622 392215 for a certificate or more information on our ISO9001 Quality Management System.



## Quality assurance

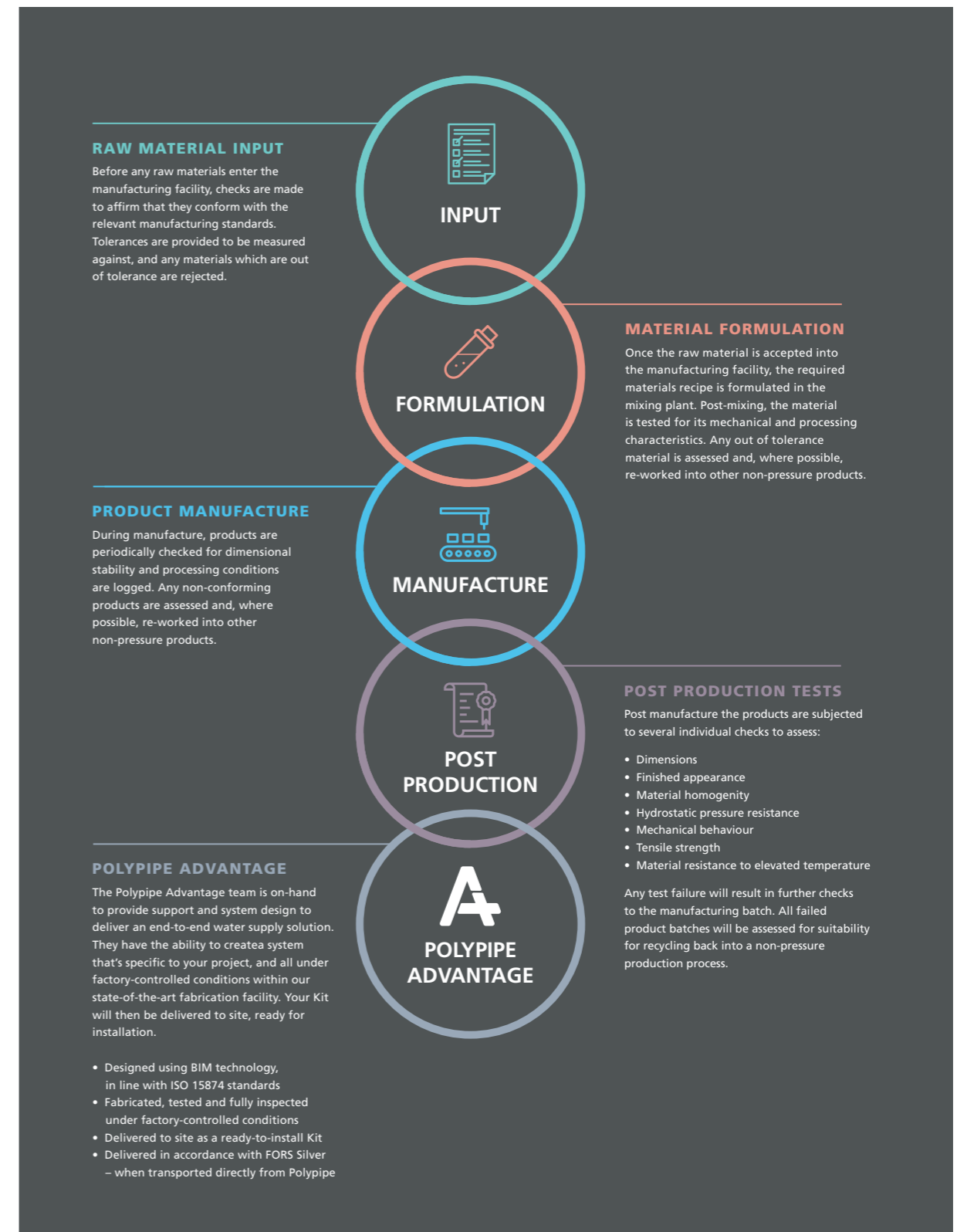

## Manufacturing standards

The MecFlow Fusion system is made to the manufacturing standards stated below. These standards set out the dimensional, physical and mechanical characteristics that each individual product shall conform to.

ISO 15874 Plastics piping systems for hot and cold water installations – Polypropylene (PP)s.

- Part 1 – General
- Part 2 – Pipes
- Part 3 – Fittings
- Part 5 – Fitness for purpose of the system
- Part 7 – Guidance for the assessment of conformity

DIN 8077 Polypropylene (PP) pipes - PP-H, PP-B, PP-R, PP-RCT – Dimensions.

DIN 8078 Polypropylene (PP) pipes - PP-H, PP-B, PP-R, PP-RCT – General Quality Requirements & Testing.

NTC 4897-2 Systems of plastic pipes for hot and cold water – Polypropylene (PP).

RP 01.00 Common requirements for AENOR Certification of Plastic Products.

RP 01.78 Special regulations of the Certificate of Conformity AENOR for Piping Systems in random polypropylene with modified crystalline structure (PP-RCT) and fiberglass (FV) for hot and cold water installations inside the structure of the Buildings.

BS EN ISO 1043-1:2011+A1:2016 Plastics. Symbols and abbreviated terms. Basic polymers and their special characteristics.

ISO 9080:2003 Plastics piping and ducting systems – Determination of the long-term hydrostatic strength of thermoplastics materials in pipe form by extrapolation.

BS EN ISO 7686:2005 Plastic pipes and fittings. Determination of opacity.



### WRAS CERTIFICATION

The MecFlow system has both WRAS material and WRAS product approval. For a copy of the certificates, please contact Polypipe Advantage team on 01622 795200 or email [mecflow@polypipe.com](mailto:mecflow@polypipe.com).

### FIRE COMPARTMENTALISATION

MecFlow has been 3rd Party tested with Polypipe Firetrap Sleeves (passive fire protection products) to achieve a 2-hour insulation and integrity compartment rating. Testing was performed at Exova, Warrington, and a test certificate can be requested through Polypipe Advantage team on 01622 795200 or email [mecflow@polypipe.com](mailto:mecflow@polypipe.com).

### FIRE CLASSIFICATION

The MecFlow system has been 3rd party tested to the standard stated below and achieved a classification of B-s1, d0. This is the highest classification that an organic material can obtain. The test was performed by AIFITI, Madrid, and a test certificate can be requested through Polypipe Advantage team on 01622 795200 or email [mecflow@polypipe.com](mailto:mecflow@polypipe.com).

BS EN 13501-1@2018 Fire classification of construction products and building elements. Classification using data from reaction to fire tests.



WRAS 1907063 –  
MecFlow Pipe and Fittings



# 11. Polypipe Advantage and MecFlow Fusion support

From design and planning to ordering, delivery, technical support and customer service, Polypipe Advantage provides everything you need to plan your project.

You'll have access to our team of dedicated Project Managers, who will work with you to create an exact delivery schedule. This means your MecFlow Fusion product reaches site exactly at the point you need it, ensuring that it can be installed straight away, with no need for storage. Simply remove the components and follow the instructions.



### SUSTAINABILITY

While our streamlined approach to fabrication can make your projects more efficient, it also offers wide-reaching sustainability benefits. Because we deliver precisely what you need, and nothing more, there are no spare parts or unnecessary extras to dispose of. We've invested heavily into sophisticated technology, ensuring our pipes are of the highest quality.

## Polypipe Advantage and MecFlow Fusion support

### ASSESSMENT, ESTIMATION AND DESIGN

Every good project begins with a thorough plan. The Polypipe Advantage team is on hand from the outset, to appraise your enquiry to identify any unique project requirements before creating a draft estimate. The Polypipe Advantage team will produce detailed CAD drawings for approval, all designs are compliant to as-drawn dimensions. This means you save vital planning time and won't have to compromise with inappropriate or over-engineered solutions.



### DISPATCH AND DELIVERY

We know that time and scheduling are critical for any project, so we ensure your system is delivered how and when you need it – while keeping you updated along the way. Our team of logistics experts work with your project timelines to ensure each element of your unique system arrives to site as scheduled, removing the need for on-site storage; leaving you to focus on installation.



### ORDERING AND FABRICATION

Once you've reviewed the design and it's finalised, our state-of-the-art fabrication and testing facility will create your system under factory-controlled conditions, ensuring only the highest quality and peace of mind for first-fix testing. All components are tested to 1.5x the site-specified design pressure and follow the method laid out in Section 9, System Commissioning.



### MERCHANT INTEGRATION

You can purchase fabricated systems from our approved Merchants, who will be happy to take your order, arrange the details with the Polypipe Advantage team – and deliver it in time for your next job.

## Polypipe Building Services

As the industry moves forward, we're here right by its side. MecFlow Fusion, which can be purchased through our Polypipe Advantage service and also distributors, is proof of our commitment to making things simple for our customers, an innovative plastic water supply system that's designed for the future.

Our website also provides useful information to keep you up to date with news and innovations as they happen, including how MecFlow Fusion can further enhance your project, whilst providing a streamlined, cost-effective, labour and time-saving alternative to traditional piping methods.

The future of supply systems starts here.

To find out more visit [polypipe.com/mecflow](http://polypipe.com/mecflow)

## Polypipe Building Services

Investing in our business and our people enables us to bring more expertise, more support and more innovation to our customers, helping them to create safe and sustainable commercial buildings, whether newbuild or refurbishment projects.

### BUILDING SERVICES SPECIALISM

Having made significant investment in expanding our portfolio to include not only our trusted and well-established Terrain drainage systems, but also MecFlow, our water supply system, we're committed to working with our customers to provide the best building services solutions for their project. From schools, hospitals and tall buildings to shopping centres, local authorities and commercial and industrial developments, we provide drainage and water supply solutions that help our customers create safe and sustainable services within buildings.

### SERVICE AND SUPPORT

Recognising the challenges the construction industry faces, we continuously research and develop products and services that enable us to support our customers more – from working with Engineers to design the best solutions for complex projects to helping Contractors overcome labour shortage issues, a lack of on-site storage and on-site waste management. We develop services to support our customers so that together, we can achieve more.

### POLYPIPE ADVANTAGE SERVICE

The Polypipe Advantage service has been specially developed to complement our products and services offering. The Polypipe Advantage team is with you every step of your project, from initial design and project planning, through to manufacture and delivery. By creating fabricated Terrain drainage and MecFlow, we're able to provide our customers quick and more efficient installations on-site. For more information on how the Polypipe Advantage service could benefit your next project, email: [mecflow@polypipe.com](mailto:mecflow@polypipe.com).

### SUPPORTING PRODUCTS AND LITERATURE

With both drainage and water supply systems in its portfolio, Polypipe Building Services has a number of solutions for your next project. More information on these systems can be found at:

[polypipe.com/commercial-building-services](http://polypipe.com/commercial-building-services)

### TAKING YOUR PROJECT FURTHER

As part of the Genuit Group, we have a number of complementary water and climate management systems available to maximise the comfort and efficiency of your commercial building:

#### Nuaire Ventilation Systems

Our Nuaire brand has been at the forefront of packaged Air Handling Units (AHUs) for over 20 years, designing and manufacturing market leading ranges. Explore the full range of Nuaire ventilation systems at [www.nuaire.co.uk](http://www.nuaire.co.uk).

#### Polypipe Underfloor Heating

Underfloor heating systems are increasingly popular and are rapidly becoming the heat source of choice for commercial and multioccupancy residential developments. For more information on our range of Underfloor Heating Systems, controls and manifolds visit: [www.polypipeUFH.com](http://www.polypipeUFH.com).

#### Polypipe: Inspiring Green Urbanisation

To help address the pressures that urbanisation and climate change place on our built environment, we've developed a new generation of technologies that sustain and optimise urban green assets through extended and fully integrated water management solutions. Systems that make space for water, alleviate flooding and capture, store and reuse rainwater, whilst enabling and inspiring Green Urbanisation. [www.polypipe.com/civils/gi](http://www.polypipe.com/civils/gi)



[polypipe.com/mecflow](http://polypipe.com/mecflow)



[polypipe.com/terrain](http://polypipe.com/terrain)



[nuaire.co.uk](http://nuaire.co.uk)



[polypipeUFH.com](http://polypipeUFH.com)



[polypipe.com/civils/gi](http://polypipe.com/civils/gi)

# Terms and conditions

## 1. GENERAL

1.1 In these conditions

1.1.1 "the Company" means Polypipe Limited, a company registered in England and Wales with registered number 1099323. Registered office: Broomhouse Lane, Edlington, Doncaster, DN12 1E5, United Kingdom.

1.1.2 "Customer" means the person with whom the Company contracts for the supply of Product pursuant to these conditions;

1.1.3 "Order" means any order submitted to the Company by a Customer;

1.1.4 "Order Confirmation" means any order confirmation submitted to the Customer by the Company;

1.1.5 "Product(s)" means the goods and/or services to be supplied by the Company as referred to and described in an Order which is accepted by the Company;

1.1.6 "Quotation" means the quotation submitted to the Customer by the Company prior to submission of an Order which details the prices at which the Customer may make an offer to purchase the Products;

1.1.7 "Writing" includes telex, cable, facsimile transmission, electronic data transfer and comparable means of communication.

1.2 A contract shall come into force between the Parties each time an Order is accepted by the Company, whether by issuing an Order Confirmation, by delivery, or otherwise, but not before. Subject to clause 1.3, (i) the terms of each contract shall be as set out in these conditions and the terms of any Order accepted by the Company, and (ii) in the event of any conflict between these conditions and any such Order, the terms of the Order shall prevail.

1.3 Save to the extent contemplated at clause 2.1, the parties agree that any terms and conditions submitted at any time by the Customer which have not been written specifically for the purposes of the Product requirement to which a specific Order relates (including, without limitation, any standard terms and conditions of purchase which are printed on any order documentation submitted by the Customer), shall not apply to any contractual dealings between the parties and shall not be deemed to constitute a counter-offer to purchase Products in accordance with those terms unless a specific intention is expressed for such terms and conditions to apply in respect of a specific Order notwithstanding this clause

1.3, and any failure by the Company to challenge or respond to any such terms and conditions does not imply and shall not constitute acceptance of those terms and conditions.

1.4 Unless otherwise stated therein Quotations shall be valid for a maximum period of 30 days from issue and may be withdrawn at any time by written or oral notice.

1.5 Any statement or representation (other than in the Company's Quotation or these terms and conditions) by the Company its servants or agents upon which the Customer wishes to rely must be set out in Writing and attached to or endorsed on the Customer's Order and in any such case the Company may confirm, reject or clarify the point and submit a new Quotation. Any statement or representation which is not so confirmed in Writing is followed or acted upon entirely at the Customer's own risk, and shall not form any part of the contract between the parties, and shall be deemed not to have influenced the Customer in deciding whether to enter into the contract.

1.6 The contract is between the Company and the Customer as principals; neither the benefit nor the burden is assignable by the Customer without the Company's written consent; the contract may be assigned or subcontracted by the Company.

1.7 Unless specifically agreed to the contrary all trade terms shall be interpreted in accordance with current INCOTERMS.

1.8 If, subsequent to any contract of sale which is subject to these conditions, a contract of sale is made with the same Customer without reference to any conditions of sale or purchase, such contract however made shall be deemed to be subject to these conditions or (if different) the standard Conditions of Sale of the Company current at the time when such contract of sale is made.

## 2. ELECTRONIC TRADING

2.1 If the Company and Customer agree that electronic trading between them shall be a basis for order processing and invoicing then these terms and conditions shall apply subject to any special terms and conditions terms which are specific to electronic trading and which have been agreed by the parties in writing.

2.2 Electronic orders shall be valid if all the information agreed between the Customer and the Company as being required is properly set out in the agreed format and the order is transmitted by the Customer to the Company by reference to the correct identification code and is received by the Company when collecting its electronic mail from the relevant system.

## 3. DELIVERY

3.1 Unless otherwise agreed in Writing by the Company delivery shall be deemed to take place in the case of ex-works sales when the Products are made available by the Company for collection by the Customer or its carrier and in all other cases upon delivery by the Company to the agreed mainland UK delivery point airport or port but before the Products are unloaded, which shall be the responsibility of the Customer.

3.2 The Company shall not be obliged to make delivery unless and until the Company has received all necessary information, drawings, final instructions and approvals from the Customer and the Customer acknowledges that any delays or alterations by the Customer may result in delayed delivery for which the Company shall not be responsible.

3.3 All dates and periods for delivery are estimated and do not constitute fixed times for delivery by the Company. Unless such a right or rights are expressly agreed in Writing by the Company, the Customer shall have no right to damages or to cancel the contract for failure arising from any cause to meet any delivery times given in the contract or subsequently set.

3.4 Notwithstanding clause 3.3 the Customer shall be obliged to accept delivery on the date or within the period stated in the Quotation or (if none is so stated) no later than one month after the issue or notice in Writing by the Company requiring the Customer to accept delivery. Failure by the Customer either to take delivery or to make payment in respect of any one or more installments of Products shall entitle the Company to terminate the Contract (such right is without prejudice to any other rights and remedies available to the Company whether expressly provided for in these Conditions or implied by any rule of law).

3.5 Where the Customer requests and the Company agrees to postpone delivery or where delivery is otherwise postponed or delayed without default by the Company, the Customer shall pay upon receipt of written demand from the Company all costs and expenses including a reasonable charge for storage and transportation occasioned thereby and the Customer shall pay for the Products in accordance with these conditions as if the same had been delivered in the ordinary course without reference to the postponement or delay. In addition, the Company shall be entitled to claim interest pursuant to Clause 7.3.2 of these Conditions from the date on which payment would have fallen due, had the Products been delivered in the ordinary course but for the postponement or delay.

3.6 Unless otherwise expressly agreed in Writing the Company may effect delivery in one or more installments. Where delivery is effected by installments each installment shall be treated as a separate contract governed by these conditions. No delay in the delivery of any installment of Products or any defect therein shall entitle the Customer to terminate the remainder of the contract.

## 4. RISK AND TITLE

4.1 Risk of damage to or loss of the Products shall pass to the Customer upon delivery and the Customer is then solely responsible for all loss damage or deterioration to the Products.

4.2 Title to the Products shall not pass to the Customer until either:-

4.2.1 The Company has received in cash or cleared funds all monies payable (whether or not due) to the Company under this and any other contracts whenever made between the Company and the Customer including contracts made after this contract; or

4.2.2 When the Company serves on the Customer notice in Writing specifying that title in the Products or any part thereof has passed.

4.3 Until title has passed to the Customer the Company may require the Customer to deliver up to the Company all products in respect of which the Company has title and if the Customer fails to do so forthwith the Company's officers, employees, representatives or agents shall be entitled to enter upon any premises where such Products are kept for the purposes of recovering the same.

4.4 Until title to the Products has passed to the Customer pursuant to these conditions it shall possess the Products as fiduciary agent and bailee of the Company and shall store the Products separately from other goods not owned by the Company and shall ensure that they are fully insured on an all risks basis and clearly identifiable as belonging to the Company and the Company shall be entitled to enter upon any premises where such Products are kept for the purpose of satisfying itself that this condition is being complied with by the Customer.

4.5 In the event that the Customer has any contract with any other company under the ultimate control of the parent company that has ultimate control of the Company under which any monies are outstanding (whether or not due) then the Customer shall not (notwithstanding that title would otherwise pass pursuant to Clause 4.2 above) obtain title to the Products or other goods supplied by the Company under this or any other contracts between them until such other company has received in cash or cleared funds all such monies.

## 5. CANCELLATION AND AMENDMENT

5.1 No contract can be amended or cancelled except with the Company's approval in Writing and should such approval be given the Customer shall indemnify the Company against any costs, losses or expenses resulting from any cancellation or amendment.

## 6. PRICES

6.1 Unless otherwise agreed in Writing all prices shall be as stated in the valid Quotation or, if no valid Quotation is in place, the Company's prevailing standard price at the time of receipt of an Order, and are for delivery ex works and are exclusive of VAT and any other applicable taxes, which are payable in addition. Unless otherwise stipulated by the Company in Writing prices are payable in Sterling or if the Sterling currency has ceased to exist when the contract is made, shall be payable in such currency as replaces the Sterling currency.

6.2 The Company will endeavour to ensure that all prices on display/provided to Customers are correct and up to date. However, should a Customer place an Order using an incorrect price then the Customer agrees that the Company may substitute the incorrect price set out in the Order for the correct price (whether the price specified on a valid Quotation or the Company's prevailing standard price, as appropriate) and charge accordingly.

6.3 The Company shall be entitled at any time by giving notice in Writing, before or after final invoicing to make a reasonable adjustment to the price in the event of any alteration in quantity, design or specification requested by the Customer.

6.4 The Company reserves the right at any time prior to delivery by giving notice in Writing to increase the price if there is any increase in the cost of materials, labour, transport, or utilities or if the costs of the Company are increased by any other factor beyond the reasonable control of the Company.

6.5 Charges made on the Company's invoice for cases will be credited on their return to the Company's premises carriage paid and in good reusable condition. Cases shown as returnable but not charged on the Company's invoice must be returned to the Company's premises carriage paid and in good re-usable condition otherwise an additional charge will be made in respect of their cost.

6.6 The Customer shall be liable to the Company for any demurrage costs incurred in the event of vehicles being unduly delayed at the point of delivery.

## 7. TERMS OF PAYMENT

7.1 Unless otherwise agreed by the Company in Writing, the Customer shall make payment by the last day of the month following the month of invoice and the Company shall be entitled to issue invoices in the month in which the Products are delivered or would have been delivered, save for postponement or delay otherwise than due to default on the part of the Company. Time for payment of the price is of the essence of the contract.

7.2 No disputes arising under this contract shall serve to permit payment by the Customer of sums due to the Company to be delayed nor shall disputes interfere with prompt payment in full. The Buyer shall not be entitled to make any deduction from or set off against any sums owing to the Company by reason of any such dispute or at all.

7.3 In the event of default in payment by the Customer the Company shall be entitled, without prejudice to any other right or remedy:

7.3.1 to suspend without notice all further deliveries on this or any other contract between the Company and the Customer;

7.3.2 to charge interest on a daily basis (after as well as before judgement) on any amount outstanding at the rate of 4% above the Base Rate of Lloyds Bank plc from time to time; and/or

7.3.3 to serve notice on the Customer requiring immediate payment for all goods supplied by the company under this and all other contracts between them whether or not payment is otherwise due or invoiced.

## 8. SPECIFICATIONS

8.1 Subject to Clause 8.2 the Products shall in all material respects be of such specification agreed between the Company and the Customer under the contract, or (if not so agreed) shall be generally in all materials respects in accordance with any published specification issued by the Company.

8.2 The Company reserves the right to make changes in dimensions or other specifications of the Products as are required to conform to applicable standards or laws or are otherwise within reasonable limits having regard to the nature of the Products. Dimensions specified by the Company are to be treated as approximate only unless it is specifically agreed in Writing that exact measurements are required.

8.3 The Customer acknowledges that it has not specified any particular use for the Products and that it is entirely its own responsibility to satisfy itself that the Product is suitable for the use which it intends.

## 9. LOSS SHORTAGES AND DAMAGE APPARENT ON DELIVERY INSPECTIONS

9.1 The Customer shall have no claim for loss, shortages or damage on delivery which are or would be apparent on inspection unless the Customer:

9.1.1 unpacks and inspects the Products as soon as reasonably practicable following receipt:

9.1.2 notifies the Company of any loss, shortages or damage (otherwise than by a qualified signature on the delivery note) within ten working days of receipt; and

9.1.3 demonstrates to the satisfaction of the Company that such loss, shortages or damage occurred prior to delivery.

9.2 The Customer shall have no rights in respect of loss, shortages or damage unless the Company is given a reasonable opportunity to inspect the Products and investigate any complaint before any use of or alteration to or interference with the Products.

9.3 On a valid complaint made in accordance with this Clause the Customer shall be entitled (in the case of notified shortages) to receive within a reasonable time a delivery of Products equivalent to the shortfall and (in the case of defects) to repairs to or replacements for the affected Products or at the Company's option a credit for the price thereof but the Company shall have no further liability whatsoever. If a complaint of loss, shortages or damage on delivery is not made to the Company in accordance with this Clause 9 within 5 working days of the date of delivery, then the Products shall be deemed to be delivered complete and undamaged in accordance with the contract and the Customer shall be bound to pay for the same accordingly.

9.4 Loss, shortages or damage in a delivery or any installment delivery shall not be a ground for termination of the contract or the remainder of the contract (as the case may be).

## 10. WARRANTY

10.1 The Company warrants that Products which do not comply with either Clause 8.1 or Sections 13 to 15 of the Sale of Goods Act 1979 (as amended) are shown to have been defective at delivery as a result of faulty design workmanship or materials (other than free-issue materials), shall either be repaired or replaced or that, at the Company's option, a credit or refund for the price thereof shall be given provided always that:

10.1.1 the Company receives written notice of the defect within 12 months of delivery;

10.1.2 no alteration to or interference with the Products takes place before the Company is given access to the Products to inspect and test the same;

10.1.3 the defect does not consist of a loss shortage or damage to which Clause 9 is expressed to apply;

10.1.4 the defect does not arise by reason of a design specification or instruction given by the Customer;

10.1.5 the Customer has not defaulted in its obligation to make payment of the contract price for the Products;

10.1.6 the defect shall not be attributable to incorrect storage or use of the Products by the Customer.

10.2 The benefit of Clause 10.1 shall only extend to Products or parts not manufactured by the Company to the extent that the Company has equivalent recourse against the manufacturer or supplier thereof.

10.3 The Customer shall indemnify the Company in respect of loss or damage arising from any use made of Products after the Customer became or ought reasonably to have been aware of a defect.

10.4 In the event of a valid claim being made in accordance with Clause 10.1:

10.4.1 the Customer shall be bound to accept repaired or replacement Products or at the Company's option credit or repayment and shall not be entitled to terminate the contract;

10.4.2 if the Company does not repair or replace Products within 60 days or such longer time as may be reasonable then the Customer's sole remedy shall be an entitlement to full credit or repayment in respect of the defective Products; and the Company shall be under no further liability in respect of any loss or damage arising from the defect or from any delay before repair replacement credit or refund is effected.

## 11. LIABILITY

11.1 The Company does not exclude liability arising under Section 12 of the Sale of Goods Act 1979 (good title) (as amended) or for death or personal injury caused by its negligence as defined in the Unfair Contract Terms Act 1977, fraudulent misrepresentation or any other type of liability which cannot by law be excluded or limited

11.2 Save as provided under Clauses 9, 10 and 11.1 the Company shall have no liability to the Customer in connection with or arising from any defect or failure in the Products or otherwise due to the quality, condition, suitability, durability, safety or any other aspect or feature of the Products. The Company's liability, whether in respect of one claim or in the aggregate, shall not exceed the contract price payable under this contract for the supply of Products to be provided under it. The price of the Products is predicated on the basis of the limitations and exclusions set out in these conditions. The Customer acknowledges that without those exclusions and limitations, the price of the Products would be higher and that the limitation of the Company's liability is therefore reasonable in all the circumstances. The Customer agrees that it is its own responsibility to insure adequately to cover any loss or damage in excess of the aforesaid limit of the Company's liability. Subject to reaching agreement on terms, the Company and the Customer may determine an increased level of liability which is to be accepted in Writing by the Company to cover, in particular specific types of loss or damage which both parties reasonably foresee and anticipate.

11.3 In Clause 11.2 the term "liability" means any form of liability whatsoever including but not limited to liability in misrepresentation and under contract, common law, equity and any statutory provision whether or not based on negligence or breach of any express or implied duty to act with care or skill.

11.4 Notwithstanding any other provisions of these conditions the Customer shall have no claim against the Company in respect of any loss other than strictly direct losses (meaning for these purposes the increased costs of purchasing products from a third party or the cost of remedial repair work) and specifically consequential, financial economic loss whether direct or indirect including but not limited to any incidental costs of dismantling fitting or other ancillary work required in connection with the provision of a repair or replacement, any loss or production profits contracts loss of use or anticipated savings and any claims made against the Customer by any third party are excluded even if reasonably foreseeable.

11.5 To the extent that any liability of the Company is expressed to be limited or excluded by these conditions the Customer shall indemnify the Company in respect thereof.

## 12. CONFIDENTIAL INFORMATION ETC.

12.1 All drawings, documents, records, computer software and other information supplied by the Company are supplied on the express understanding that all intellectual property rights therein is reserved to the Company and that the Customer will not without written consent of the Company either give away, loan, exhibit, or sell the same or extracts therefrom or copies thereof or use the same in any way except in connection with the Products in respect of which they are issued.

## 13. PATENT INDEMNITIES

13.1 If the Customer is subject to a claim or threatened with any action alleging that the Products in the form supplied infringe any patent, copyright, design right or other intellectual property right then provided that the Customer promptly informs and fully co-operates with the Company and if requested allows the Company the conduct and defence thereof on the Customer's behalf, the Company will indemnify the Customer against any award or damages for infringement made in any such action by a court or other competent body against the Customer. Further, if the Products are infringing the Customer agrees that the company shall have the option at its own expense either to modify the Products so that they do not infringe: to replace the Products with a non-infringing substitute: to procure for the Customer the right for the Customer to continue its use of the Products: or to repurchase the Products from the Customer at the price paid by the Customer less an allowance for the use made thereof.

13.2 The Company shall have no liability in respect of claims for infringement or alleged infringement of third parties patent or other intellectual property rights arising from the manufacture or supply of the Products to the Customer's instructions or in accordance with designs plans or specifications given by the Customer and the Customer shall indemnify the Company against all losses damages expenses costs or other liability arising from such claims.

## 14. CUSTOMER'S DRAWINGS

14.1 The Customer shall be solely responsible for ensuring that all drawings information advice and recommendations specified or given to the Company by the Customer or its agents, servants, consultants or advisers are accurate correct and suitable. Examination or consideration by the Company of such drawings information advice or recommendations shall not result in any liability on the part of the Company.

## 15. COMPANY LITERATURE

15.1 The information contained in the advertising, sales, technical, and other literature issued by the Company may be relied upon to be accurate in the exact circumstances in which it is expressed otherwise any illustrations performance details examples of installations and methods of assembly and all other information and data in such literature are based on experience and upon trials under test conditions and are provided for general guidance only. No such information or data shall form part of the contract unless it is specifically referred to in the Quotation.

## 16. TERMINATION

16.1 Without prejudice to any other rights or remedies of the Company it shall be entitled in any of the following circumstances to terminate (in whole or in part) this and any other contract whenever made between the Company and the Customer and/or to suspend deliveries and/or to receive upon demand payment of all monies payable under any such contracts whether or not otherwise due:

16.1.1 The Customer made or proposes any voluntary arrangement with its creditors or becomes subject to an administration order or becomes bankrupt or goes into liquidation;

16.1.2 an encumbrancer takes possession or a receiver is appointed of any of the property or assets of the Customer;

16.1.3 the Customer becomes unable to satisfy its debts as they fall due or cease, or threatens to cease to carry on business;

16.1.4 the Company reasonably believes that any of the events mentioned above or any equivalent or similar event under any relevant laws to which the Customer or any connected person is subject has or may occur;

16.1.5 the Customer or any connected person commits any breach of this or any other contract whenever made between the Customer and the Company.

## 17. FORCE MAJEURE

17.1 The Company shall be excused performance of its obligations whilst and if affected by act of God governmental restriction condition or control, any act done or not done pursuant to a trade dispute whether such dispute involves its employees or not, default by suppliers of the Company, shortage of materials or by any other act matter or thing beyond its reasonable control including failure by the other party to carry out anything required for performance of the contract.

17.2 In the event that the Company does not perform its obligations by reason of any of the causes referred to in Clause 17.1 within six months after the time for performance then the Company or the Customer may by written notice terminate the contract without liability save that the Customer shall pay for any Products delivered or completed at the time of termination.

## 18. TOOLS

18.1 Any tools (such as jigs, dies, etc) which the Company may construct or acquire specifically in connection with the Products shall, notwithstanding any charges the Company may make for them, be and remain the Company's sole and unencumbered property and in the Company's possession and control without restriction.

## 19. FREE-ISSUE MATERIAL

19.1 Free-issue material shall be insured by and remain at the risk of the Customer at all times and the Company shall be indemnified by the Customer against any loss, damage, injury or expense whatsoever arising directly or indirectly therefrom and the company shall not be liable for loss of or damage to any such materials during fabrication by the Company or sub-contractor employed by Company or whilst on the premises of the Company or of any such sub-contractor or in transit to or from the premises of the Company or of any such sub-contractor provided that the Company may at its sole discretion make a contribution towards the replacement costs of such materials.

19.2 An allowance for material lost as process scrap is (where applicable) included in the contract price and no such losses shall be the subject of any claim by the Customer or contribution by the Company.

19.3 Where materials are supplied by or on behalf of the Company the Customer shall be responsible to ensure that the material is of satisfactory quality and is fit for its purpose and shall indemnify be Company against any loss damage, injury or expenses whatsoever arising directly or indirectly from any fault in or incorrect specification of the said materials.

**20. CONSUMER PROTECTION ACT 1987**

20.1 Where the Customer purchases the Products for use or incorporation with any other products to be assembled, produced, processed packed or supplied by the Customer or for resale or supply ancillary to any such other products or other products supplied by the Customer then:

20.1.1 the Customer shall forthwith on demand produce for inspection by the Company copies of all written instructions information and warnings to be supplied by the Customer in relation thereto provided nevertheless that such inspection or right to inspect shall not give rise to any responsibility or liability on the part of the Company; and 20.1.2 the Customer shall indemnify the Company against any losses, costs and damages that the Company may suffer or incur in the event any claim is made against the Company in relation thereto if the Products did not comprise the defective element thereof or were rendered defective by reason of actions or omissions of the Customer (including without limitation the supply of defective free-issue materials) or were rendered defective by reason of instructions or warnings given or omitted by the Customer or other reseller.

20.2 For the purpose of Clause 20.1 the term "defective" shall be interpreted in accordance with the definition contained in Part 1 of the Consumer Protection Act 1987.

**21. HEALTH & SAFETY**

21.1 The Customer agrees to pay due regard to any information supplied by the Company relating to the use for which the Products are designed or have been tested or concerning conditions necessary to ensure that they will be safe and without risk to health at all times when they are being set, used, cleaned, serviced or maintained by any person and the Customer undertakes to take such steps as may be specified by such information or otherwise necessary to ensure that as far as is reasonably practicable the Products will be safe and without risk to health at all times as mentioned above.

**22. LAW AND JURISDICTION ETC.**

22.1 The Contract shall be governed and interpreted exclusively according to the Laws of England. The parties hereby agree to submit to the exclusive jurisdiction of the English courts provided that the Company may at its option take proceedings in the courts of the state in which the Customer is domiciled including action to obtain any remedy (including injunctive relief). In the case of any order for the export of Products, the Schedule to the Uniform Law on International Sales Act 1967 shall not in any circumstances apply to the Contract and neither shall the limits imposed by the Unfair Contract Terms Act 1977 on the extent to which liability can be excluded or limited.

22.2 No waiver of or delay or failure by the Company to exercise any rights or remedies shall prejudice or preclude any future or further exercise thereof.

22.3 If any provision of these conditions shall be held invalid or unenforceable in whole or in part then the unaffected provisions shall remain in full force and effect. Headings appear for convenience only and shall not affect the Construction of these conditions.

22.4 If the Contract provides for the supply of services and no general conditions of the Company relating specifically to the supply of services are made applicable to such services then these conditions shall mutatis mutandis apply to such services as they would apply to Products and in such event Clause 10.1 will be deemed to include a reference to Sections 3 to 5 of the Supply of Goods and Services Act 1982 (as amended), either in addition to or in place of the reference to Sections 13 to 15 of the Sale of Goods Act 1979 (as amended) as may be appropriate. For the avoidance of doubt the following provisions apply where the Company supplies services to the Customer in accordance with clause 22.4:-

22.4.1 the Company's obligation to provide the services is in any event conditional upon payment of the agreed price for the services. Any default or delay in payment according to the terms agreed between the Company and the Customer shall entitle the Company at its option to decline to perform or decline to continue to perform its obligations hereunder but without thereby incurring any liability to the Customer.

22.4.2 Save to the extent that by reason of negligence on the part of the Company in the performance of the services which results in death or personal injury (which the Company does not limit or exclude), the Company's liability under the contract shall be limited to the amount of charges paid to the Company in return for the services and in particular the Company accepts responsibility only for direct and unavoidable loss or damage arising from any negligence in the provision of services and in particular all other types of loss whether economic, financial, indirect or consequential and whether reasonably foreseeable or not are excluded to the fullest extent permitted by law.

22.4.3 The Customer shall lend all such reasonable assistance to the Company in the performance of the services as the Company shall reasonably require.

22.4.4 The Customer shall indemnify and keep the Company, its employees, agents and contractors indemnified at all times from and against any loss or damage and injury caused to persons or property in the course of the provision of the services where such loss or damage arises by reason of the Customer's negligence or negligence of persons under the control of the Customer.

22.4.5 The Customer acknowledges and agrees that if due to the act or omission of the Customer, the Company is not able, having attended at the Customer's premises to perform the services, the Company shall be entitled to claim reasonable additional costs and expenses from the Customer occasioned by any resulting delay in the provisions of the services.

22.5 In cases for the sale or supply of Products overseas, the following additional provisions shall apply unless otherwise stipulated in writing by the Company:

22.5.1 the Customer shall be solely responsible for obtaining all necessary import authorisations, the payment of any applicable import taxes, duties or imposts and the Company shall be under no obligation to give the Customer the notice specified in Section 32(3) of the Sale of Goods Act 1979 (or any re-enactment thereof);

22.5.2 Quotations issued in a currency other than Sterling may at the Company's option, unless otherwise agreed in writing, be subject to amendment in the event of fluctuations in the applicable exchange rate prior to the date of invoice;

22.5.3 payment in respect of Products for export is due on the date specified by the Company at the date when the Contract is made, in the currency stated in the invoice and in accordance with the method of payment stipulated by the Company. All costs incurred by the Company in connection with the designated particular method of payment shall be met by the customer.

22.5.4 If you are a consumer within the meaning of the Distance Selling Regulations 2000 and you have bought the products detailed overleaf over telephone, internet or via mail order then within seven days of receipt of your products you have the right to cancel your order and return the Products for a full refund. Trading terms were accurate at point of publication, to check for updates, please go to Trading Terms & Conditions at [www.Polypipe.com/trading-terms-conditions](http://www.Polypipe.com/trading-terms-conditions).

NOTES

Horizontal lines for notes.

**MECFLOW**

**SUPPLY  
SYSTEMS**

## The future of supply systems

MECFLOW FUSION DESIGN,  
SPECIFICATION AND INSTALLATION GUIDE



### Polypipe Building Services

New Hythe Business Park

College Road

Aylesford

Kent

ME20 7PJ

Tel +44 (0) 1622 795200

Email [commerciaLENquiries@polypipe.com](mailto:commerciaLENquiries@polypipe.com)

[www.polypipebuildingservices.com](http://www.polypipebuildingservices.com)